

## Condair DL II

### ERSATZTEILE / SPARE PARTS / PIECES DE RECHANGE

Änderungen vorbehalten! / Subject to change! / Modifications réservées!

Pos	Artikel/Article/Article	Zusatz / Completion / Complément	Art.-/SAP-No.
<b>Zentraleinheit / Central unit / Unité centrale</b>			
101	Einlass Magnetventil 24VDC Inlet solenoid valve 24VDC Vanne d'admission 24VDC		2579725
102	Leitfähigkeitssensor Conductivity sensor Capteur de conductivité		1105386
103	O-Ring O-ring Joint torique		2579726
104	Drucksensor (2 Stk.) Pressure sensor (2 pcs) Senseur pression (2 pcs)		2579727
105	O-Ring (2 Stk.) O-ring (2 pcs) Joint torique (2 pcs)		2579728
106	Manometer Manometer Manomètre		1116201
107	Einschraubstutzen (2 Stk.) Stem adapter (2 pcs) Douille de jonction (2 pcs)	Ø 12 mm - 3/8"	2579729
108	L-Einsteckverbinder (5 Stk.) Stem L-connector (5 pcs) Raccord tige coudé (5 pcs)	Ø 12 mm	1118793
109	Einschraubverbinder NIRO (1 Stk.) Male connector stainless steel (1 pcs) Union simple mâle INOX (1 pcs)	Ø 12 mm - 3/8"	2579730
110	L-Verbinder (5 Stk.) L-connector (5 pcs) Raccord coudé (5 pcs)	Ø 12 mm	1118795
112	Wasserfilter komplett Water filter complete Filtre d'eau complete		2579731
113	O-Ring Wasserfilter O-ring water filter Joint torique filtre d'eau		2579688
114	Filtereinsatz Water filter Filtre d'eau		2579689
115	Set Silberionisierung Hygiene Plus Set silver ionisation Hygiene Plus Set ionisation argent Hygiène Plus	Typ / Type / Type 30 Typ / Type / Type 60 Typ / Type / Type 125 Typ / Type / Type 250 Typ / Type / Type 500	2602477 2602478 2602479 2602480 2602481
	Set Silberionisierung Hygiene Plus, Zulassung Schweiz Set silver ionisation Hygiene Plus, Approval Switzerland Set ionisation argent Hygiène Plus, Approbation Suisse	Typ / Type / Type 30 Typ / Type / Type 60 Typ / Type / Type 125 Typ / Type / Type 250 Typ / Type / Type 500	1117441 1117442 1117443 1117450 1117448

Pos	Artikel/Article/Article	Zusatz / Completion / Complément	Art.-/SAP-No.
	Set Silberionisierung Hygiene Plus, Zulassung Deutschland Set silver ionisation Hygiene Plus, Approval Germany Set ionisation argent Hygiène Plus, Approbation Allemagne	Typ / Type / Type 30 Typ / Type / Type 60 Typ / Type / Type 125 Typ / Type / Type 250 Typ / Type / Type 500	2519259 2519260 2519261 2519262 2519263
116	Schottverbinder (4 Stk.) Bulkhead connector (4 pcs) Traversée par cloison (4 pcs)	Ø 10 mm - 1/2"	1118934
117	Schottverbinder Bulkhead connector Traversée par cloison	Ø 12 mm - 3/4"	1118935
118	L-Einsteckverbinder (5 Stk.) Stem L-connector (5 pcs) Raccord tige coudé (5 pcs)	Ø 10 mm	2533070
119	Wandhalterung Wall support Porte mural		2579690
120	Wasserstrahlpumpe komplett Ejector pump complete Ejecteur à eau complete		2579691
121	Verbindungsleitung Wasserstrahlpumpe Connection ejector pump Joncteur éjecteur à eau		2579692
122	Ventilblock komplett Valve block complete Bloc de vanne complète	3 Sprüh-Ventile / spray valve / vanne d'atomisation 4 Sprüh-Ventile / spray valve / vanne d'atomisation 5 Sprüh-Ventile / spray valve / vanne d'atomisation 6 Sprüh-Ventile / spray valve / vanne d'atomisation	2579693 2579973 2579974 2594723
123	Ventilblock Oberteil Valve block upper component Bloc de vanne partie supérieure	3 Sprüh-Ventile / spray valve / vanne d'atomisation 4 Sprüh-Ventile / spray valve / vanne d'atomisation 5 Sprüh-Ventile / spray valve / vanne d'atomisation 6 Sprüh-Ventile / spray valve / vanne d'atomisation	2579697 2579975 2579976 2594724
124	Ventilblock Unterteil Valve block bottom part Bloc de vanne embase	3 Sprüh-Ventile / spray valve / vanne d'atomisation 4 Sprüh-Ventile / spray valve / vanne d'atomisation 5 Sprüh-Ventile / spray valve / vanne d'atomisation 6 Sprüh-Ventile / spray valve / vanne d'atomisation	2579698 2579977 2579978 2594726
125	Magnetspule Coil drain valve Electro-aimant vanne		2578825
—	Verbindungskabel Magnetspule für 2594723 Connection cable solenoid coil for 2594723 Câble de connexion électro-aimant pour 2594723		2594727
127	Einschraubverbinder NIRO (5 Stk.) Male connector stainless steel (5 pcs) Union simple mâle INOX (5 pcs)	Ø 6 mm - 1/8"	2556816
128	L-Verbinder (5 Stk.) L-connector (5 pcs) Raccord coudé (5 pcs)	Ø 6 mm	1120279
129	L-Verbinder (5 Stk.) L-connector (5 pcs) Raccord coudé (5 pcs)	Ø 10 mm	1119785
130	Schlauch EPDM Hose EPDM Tuyau EPDM	Ø 12 mm	2579905
131	PA-Rohr PA tube Tuyau PA	Ø 12 mm, L = 3 m	2579700
132	Wasseranschluss-Set Water connection kit Set de connexion entrée d'eau		2579701
133	Einschraubverbinder NIRO (5 Stk.) Male connector stainless steel (5 pcs) Union simple mâle INOX (5 pcs)	Ø 8mm 1/8"	2580110

Pos	Artikel/Article/Article	Zusatz / Completion / Complément	Art.-/SAP-No.
134	Stopfen (4 Stk.) Plug (4 pcs) Bouchon (4 pcs)		2579702
135	T-Verbinder (5 Stk.) T-connector (5 pcs) Raccord-T (5 pcs)	Ø 12 mm	1118792
136	L-Einsteckverbinder (5 Stk.) Stem L-connector (5 pcs) Raccord tige L (5 pcs)	Ø 6 mm	1116174
137	Wasserablauf-Set Water drain kit Set de connexion sortie d'eau		2583655
138	Frontabdeckung Zentraleinheit Front cover central unit Face avant unité centrale		2603505
139	Block Manometer, inklusive Verschraubung und O-Ringe Block manometer, fitting and O-rings included Bloc manomètre, avec vissage et joint toriques		2591855
140	Block Sensor Düsendruck, inklusive Verschraubung und O-Ring Block sensor nozzle pressure, fitting and O-ring included Bloc senseur pression, avec vissage et joint torique		2591856
141	Block Druckschalter, inklusive Verschraubung und O-Ring Block pressure switch, fitting and O-ring included Bloc mancontacteur à pression, avec vissage et joint torique		2591857
142	Halterung Hygiene Plus Holder Hygiene Plus Support Hygiene Plus		2613698
201	Drehschieberpumpe Rotary vane pump Pompe à tiroirs rotatifs	73 l/h @ 2300 1/min 170 l/h @ 2300 1/min 390 l/h @ 2300 1/min 925 l/h @ 2300 1/min 1167 l/h @ 2300 1/min	2579706 2579707 2579708 2579709 2579710
202	Pumpenmotor Pump motor Moteur pompe	0.37 kW 0 - 170 l/h 0.55 kW >170 l/h - 390 l/h 0.75 kW >390 l/h - 1167 l/h	2579711 2579712 2579713
203	Befestigung Pumpe Pump support Fixage pompe		2579714
204	Druckschalter Pressure switch Manocontacteur à pression		1116199
205	Rückschlagventil Check valve Soupape de retenue	ø12	2579716
206	Einschraub-Verbinder (1 Stk.) Screw-type connector (1 pcs) Raccord vissé (1 pcs)	ø12 - 3/8" (≤ 390 l/h) ø12 - 1/2" (> 390l/h)	2580111 2580112
207	Adapter Pumpe Adapter pump Adaptateur pompe		2579717
208	Nabe Boss Moyeau	≤ 170 l/h > 170 l/h	2579718 2579719
209	O-Ring O-ring Joint torique		2579720
210	Ringschlüssel für Wasserfilter Ring wrench for water filter Clé polygonale pour filtre d'eau		2584810
211	Adapter Filtergehäuse inkl. Dichtungen (2 Stk.) Adaptor filter housing with gaskets (2 pcs) Adaptateur de boîtier de filtre avec joints (2 pcs)		2604926

Pos	Artikel/Article/Article	Zusatz / Completion / Complément	Art.-/SAP-No.
—	Kabelbaum Zentraleinheit Cable tree central unit Faisceau de câbles unité centrale	1 Meter / mit Pumpe / with pump / avec pompe 1 Meter / ohne Pumpe / without pump / sans pompe 5 Meter / mit Pumpe / with pump / avec pompe 5 Meter / ohne Pumpe / without pump / sans pompe	2580605 2580606 2580607 2580608
—	Kabelbaum Zentraleinheit inkl. Drossel Cable tree central unit incl. reactor Faisceau de câbles unité centrale incl. inductance d'arrêt	10 Meter / mit Pumpe / with pump / avec pompe 10 Meter / ohne Pumpe / without pump / sans pompe	2580609 2580610
<b>Steuereinheit / Control unit / Unité de commande</b>			
301	Treiberplatine Driverboard Platine de pilotage		2579733
302	Platine Leitfähigkeitsüberwachung Conductivity Board Platine de conductivité		2579734
303	Platine Silberionisierung Silver ionization board Platine ionisation argent		2579735
304	Betriebs- und Störungsfernmeldung Remote operating and fault indication Télésignalisation d'exploitation et de dérangement		2603503
305	Integrated controller mit Touchpanel (Steuerplatine) Integrated controller with touchpanel (Control board) Integrated controller avec touchpanel (Platine de commande)		2603504
309	Frequenzumrichter Frequency converter Convertisseur de fréquence	für Motor/for motor/pour moteur 0.37 kW für Motor/for motor/pour moteur 0.55 kW für Motor/for motor/pour moteur 0.75 kW	2580630 2580629 2579738
310	Leckage Melder Leak indicator Indicateur de fuite		2566935
311	Stecksockel für Leckagemelder Base leak indicator Socle indicateur de fuite		2553226
312	Netzfilter Line Filter Filtre d'alimentation		2579739
313	Kabelverschraubung EMV NIRO Cable clamp EMC stainless steel Presse-étoupe CEM INOX	M20 x 1.5	2579740
314	Kabeleinführungsleiste Cable entry frames Passage de câble		2579741
315	Schalter Switch Interrupteur		2579742
316	Kabelverschraubung (5 Stk.) Cable clamp (5 pcs) Presse-étoupe (5 pcs)	M20 x 1.5	2579743
317	Ferritring teilbar Snap Ferrite Ferrites à clapet		2579744
318	Netzteil Power supply Alimentation électrique		2579745
319	Netztrennschalter Befeuchter Disconnecting switch humidifier Sectionneur humidificateur		2564847
320	Anschlussklemmen L N 2xPE Connecting terminal L N 2xPE Borne de connection L N 2xPE		2579746

Pos	Artikel/Article/Article	Zusatz / Completion / Complément	Art.-/SAP-No.
321	Schliessbolzen komplett Cotter pin complete Bouton de fermeture		2590984
322	Verdrahtungskanal Cable conduit Conduit de câbles	L = 150 mm	2579748
323	Verdrahtungskanal Cable conduit Conduit de câbles	L = 300 mm	2579749
324	Drossel Reactor coil Inductance d'arrêt	Nur bei verlängertem Kabelbaum mit Pumpe Only by extended cable tree avec pump Seul. pour faisceau de câbles prolongée avec pomp	2579750
325	Frontabdeckung Steuereinheit Front cover control unit Face avant unité de commande		2603501
326	Innere Schwenktüre Inner swing door Porte basculante intérieure		2603506
327	Gleitlager (2 Stk.) und Magnet Slide bearings (2 pcs) and magnet Glissières (2 pcs) et aimant		2603507
328	Verschlussclip Locking clip Clip de verrouillage		2601040
—	Kabelbaum Steuereinheit Cable tree control unit Faisceau de câbles unité de commande		2603502
—	Lecksensor Leak sensor Senseur de fuite		2580638
—	Sensorkabel Lecküberwachung Cable sensor leak monitoring Câble de surveillance des fuites	1.5 m 3.0 m 13.0 m	2595349 2595350 2595348
—	Smart Card Smart Card Smart Card		2584599
<b>Düsensystem / Nozzle system / Système des buses</b>			
401	Düse mit O-Ring (3 Stk.) Nozzle with O-ring (3 pcs) Buse avec joint torique (3 pcs)	1.5 l/h 2.0 l/h 2.5 l/h 3.0 l/h 3.5 l/h 4.0 l/h 4.5 l/h 5.0 l/h	2579752 2594363 2579754 2579756 2594364 2579757 2594365 2579759
402	O-Ringe Düse (2x 20 Stk.) O-rings nozzle (2x 20 pcs) Joint torique buse (2x 20 pcs)	aussen+innen / outside+inside / extérieur+intérieur	2577916
403	Düsenhalter (2 Stk.) Nozzle support (2 pcs) Support pour buse (2 pcs)		2579764
404	L-Verbinder (5 Stk.) L-connector (5 pcs) Raccord coudé (5 pcs)	ø 8 mm	1118794
405	T-Verbinder (5 Stk.) T-connector (5 pcs) Raccord-T (5 pcs)	ø 8 mm	1118752
406	Set Kennzeichnungshülsen (10 Stk.) Set designation bushings (10 pcs) Set cosse de codification (10 pcs)	rot / red / rouge blau / blue / bleue gelb / yellow / jaune grün / green / verte	1117730 1117731 1117732 2579699

Pos	Artikel/Article/Article	Zusatz / Completion / Complément	Art.-/SAP-No.
407	Haltebügel (4 Stk.) Holder (4 pcs) Etrier de blocage (4 pcs)		2579766
408	Befestigungsplatte (2 Stk.) Mounting plate (2 pcs) Plateau de fixation (2 pcs)		2579769
409	Versteifungsplatte (2 Stk.) Reinforcement plate (2 pcs) Plateau de renforcement (2 pcs)		2579771
410	Wanddurchführung Wall lead through Passage de boîtier	L = 75 mm L = 125 mm	1118875 2557823
411	Dichtung Wanddurchführung (3 Stk.) Gasket wall lead through (3 pcs) Joint passage de boîtier (3 pcs)		2579774
412	PA-Schlauch (pro Meter) PA tube (per meter) Tuyau PA (par mètre)	ø 10 mm	1117738
413	PA-Schlauch (pro Meter) PA tube (per meter) Tuyau PA (par mètre)	ø 8 mm	1102840
414	L-Einschraubverbinder (5 Stk.) Screw-type L-connector (5 pcs) Raccord vissé L (5 pcs)	ø 8 mm - 1/4"	1116173
	L-Einschraubverbinder NIRO (1 Stk.) Screw-type L-connector stainless steel (1 pcs) Raccord vissé L INOX (1 pcs)	ø 8 mm - 1/4"	2556818
415	L-Einschraubverbinder (5 Stk.) Screw-type L-connector (5 pcs) Raccord vissé L (5 pcs)	ø 10 mm - 1/4"	1118162
	L-Einschraubverbinder NIRO (1 Stk.) Screw-type L-connector stainless steel (1 pcs) Raccord vissé L INOX (1 pcs)	ø 10 mm - 1/4"	2556819

#### Nachverdunstereinheit / Post evaporation unit / Unité posthumidification

501	Keramikplatte links Ceramic plate left Plaque de céramique à gauche	200 x 250 mm	2578830
		250 x 250 mm	2578831
		200 x 300 mm	2578832
		250 x 300 mm	2578833
		200 x 410 mm	2578834
502	Keramikplatte rechts Ceramic plate right Plaque de céramique à droite	250 x 410 mm	2578835
		200 x 250 mm	2578836
		300 x 250 mm	2578837
		400 x 250 mm	2578838
		200 x 300 mm	2578839
		300 x 300 mm	2578840
		400 x 300 mm	2578841
503	Keramikplatte mitte <sup>1)</sup> Ceramic plate middle <sup>1)</sup> Plaque de céramique centre <sup>1)</sup>	200 x 410 mm	2578842
		300 x 410 mm	2578843
		400 x 410 mm	2578844
		300 x 250 mm	2578845
		500 x 250 mm	2578846
		300 x 300 mm	2578847
		500 x 300 mm	2578848
300 x 410 mm	2578849		
		500 x 410 mm	2578850

<sup>1)</sup> Hinweis: Keramikplatten mit einer Breite von 700 mm sind nicht mehr lieferbar. Müssen solche Keramikplatten ersetzt werden, ist die gesamte Reihe mit neuer Keramikplatten-Kombination auszutauschen.  
Note: Ceramic plates with a width of 700 mm are no longer available. If such ceramic plates need to be replaced, the entire row of plates must be replaced with a new ceramic plate combination.  
Remarque : Les plaques céramiques d'une largeur de 700 mm ne sont plus disponibles. Si de telles plaques céramiques doivent être remplacées, toute la rangée doit être remplacée par une nouvelle combinaison de plaques céramiques.

Pos	Artikel/Article/Article	Zusatz / Completion / Complément	Art.-/SAP-No.
504	Abdichtblech seitlich Sealing plate lateral Tôles d'étanchéité latéral	L = 325 mm	2579776
		L = 650 mm	2579777
		L = 990 mm	2579778
505	Befestigungsprofil Abdichtung seitlich Mounting bracket sealing lateral Equerre tôles d'étanchéité latéral	L = 150 mm	2590387
		L = 250 mm	2590388
		L = 400 mm	2579780
		L = 500 mm	2579782
		L = 600 mm	2579787
		L = 700 mm	2579788
506	Abdichtblech oben Sealing plate top Tôles d'étanchéité au-dessus	L = 300 mm	2579790
		L = 600 mm	2579791
507	Befestigungsprofil Decke Fastening profile top Tôle de fixation plafond	L = 250 mm	2579792
		L = 660 mm	2579793
508	Haltebügel Keramikträger (2 Stk.) Holder ceramic carrier (2 pcs) Etrier de blocage céramique (2 pcs)	links + rechts left + right à gauche + à droite	2579794
509	Keramik Trägerprofil Ceramic carrier profile Support céramique	L = 375 mm	2583540
		L = 450 mm	2579795
		L = 525 mm	2583541
		L = 600 mm	2579796
		L = 675 mm	2583542
		L = 750 mm	2579797
		L = 825 mm	2583543
		L = 900 mm	2579798
		L = 975 mm	2583544
		L = 1050 mm	2579799
		L = 1125 mm	2583545
		L = 1200 mm	2579800
		L = 1275 mm	2583546
		L = 1350 mm	2579801
		L = 1425 mm	2583547
L = 1500 mm	2579802		
510	Halterung (2 Stk.) Support (2 pcs) Support (2 pcs)		2579803
511	Gummidichtung unten (pro Meter) Bottom rubber sealing (per meter) Joint en caoutchouc en bas (par mètre)	H = 200 mm	2577314
		H = 300 mm	1119940
		H = 450 mm	2519747
512	Keramik Abstützprofil Ceramic support profile Cale pour céramique	L = 375 mm	2583552
		L = 450 mm	2579804
		L = 525 mm	2583553
		L = 600 mm	2579805
		L = 675 mm	2583554
		L = 750 mm	2580597
		L = 825 mm	2583555
		L = 900 mm	2580596
		L = 975 mm	2583556
		L = 1050 mm	2580598
		L = 1125 mm	2583557
		L = 1200 mm	2580599
		L = 1275 mm	2583558
		L = 1350 mm	2580600
		L = 1425 mm	2583559
L = 1500 mm	2580601		
L = 1610 mm	2583560		
L = 1720 mm	2583561		
L = 1830 mm	2583562		
L = 1940 mm	2583563		
513	Klammer (10 Stk.) Clip (10 pcs) Clip (10 pcs)		2579806
514	Winkelhalter Angle bracket Equerre		2579807

Pos	Artikel/Article/Article	Zusatz / Completion / Complément	Art.-/SAP-No.
515	Verschraubung (30 Stk.) Fittings (30 pcs) Vissage (30 pcs)		2579808
516	Stützfuss Leg support Support à pied		2583378
517	Befestigungswinkel für seitliche Trägerprofile und Querträger Mounting bracket for lateral supports and cross members Support de mont. pour profils de supp. latéraux et barres transvers.	L = 300 mm L = 400 mm L = 500 mm L = 600 mm L = 700 mm L = 800 mm L = 900 mm L = 1000 mm L = 1100 mm L = 1200 mm L = 1300 mm L = 1400 mm L = 1500 mm L = 1600 mm L = 1700 mm L = 1800 mm L = 1900 mm L = 2000 mm	2595501 2595502 2595503 2595504 2595505 2595506 2595507 2595508 2595513 2595511 2595514 2595516 2595517 2595518 2595519 2595520 2595521 2595512
518	Diagonalstrebe Diagonal stiffeners Attelle diagonal		2602717
519	Bodenblech Base plate Tôle de plancher	390 mm 990 mm	2613586 2613588
—	Bohrschrauben (30 Stk.) Drilling screws (30 pcs) Vis autoperceuse (30 pcs)		2579715

Zentraleinheit Typ A mit Sterilfilter  
 Central unit Type A with sterile filter  
 Unité centrale Type A avec filtre stérile

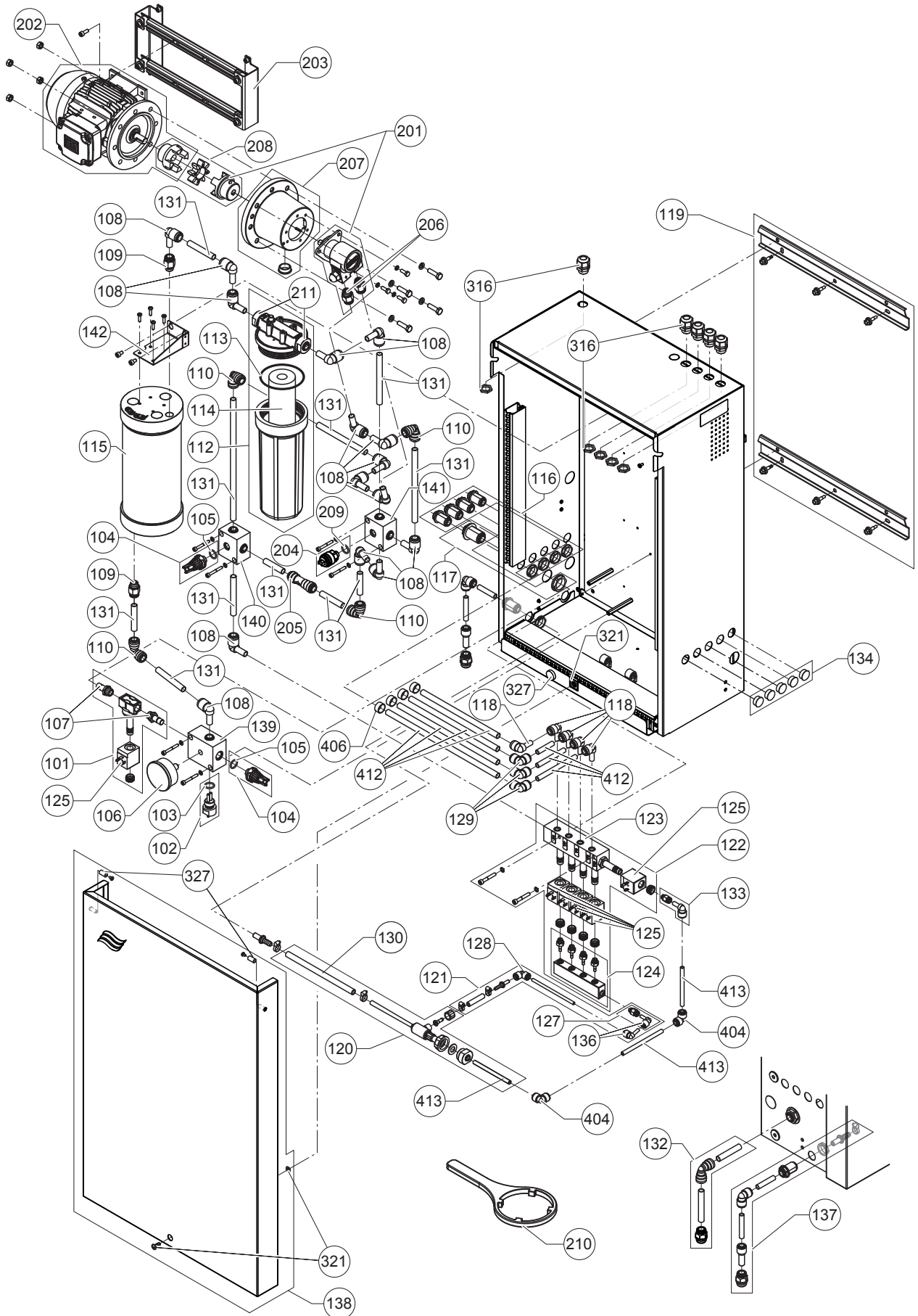

Zentraleinheit Typ A ohne Sterilfilter  
 Central unit Type A without sterile filter  
 Unité centrale Type A sans filtre stérile

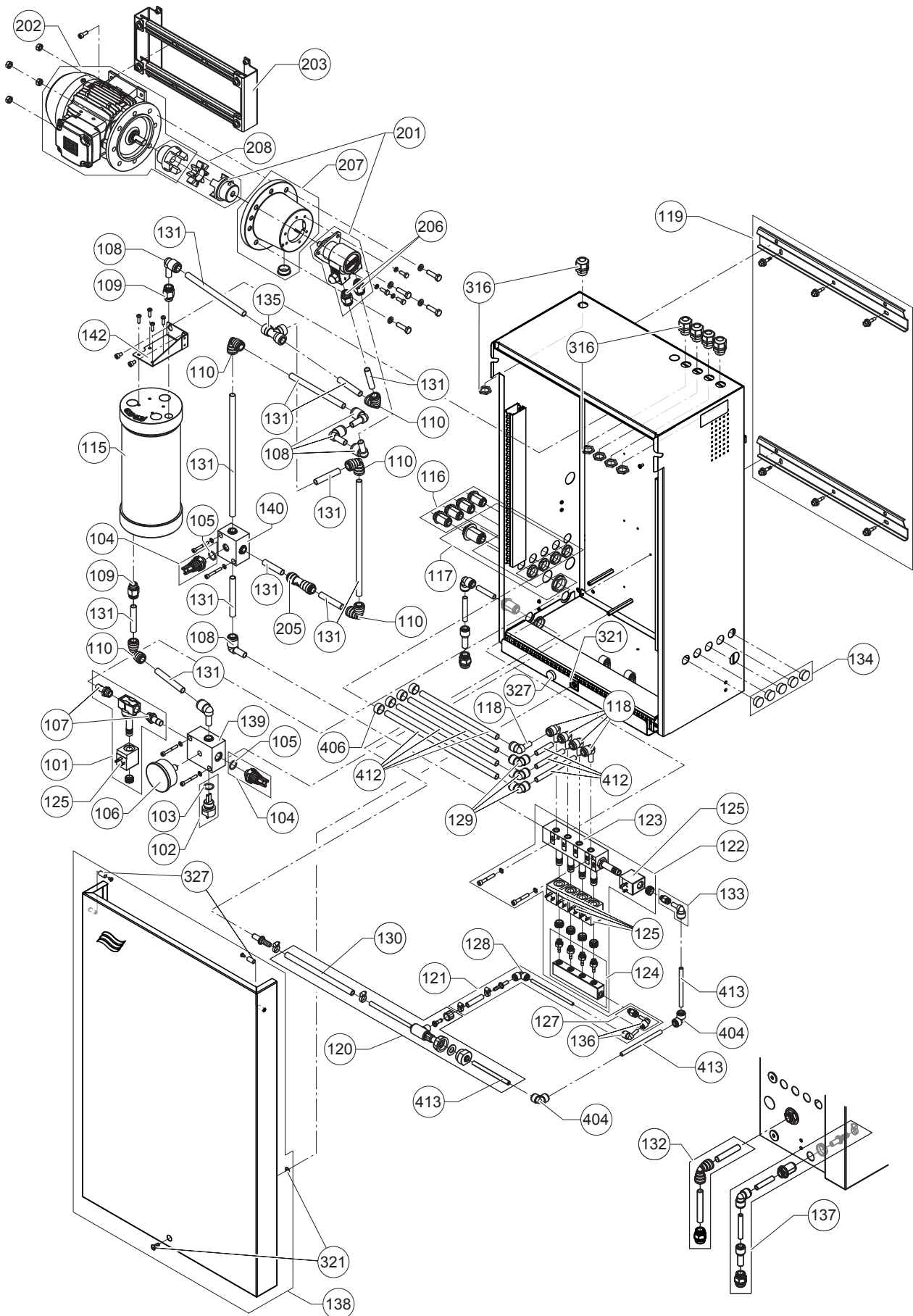

Zentraleinheit Typ B mit Sterilfilter  
 Central unit Type B with sterile filter  
 Unité centrale Type B avec filtre stérile

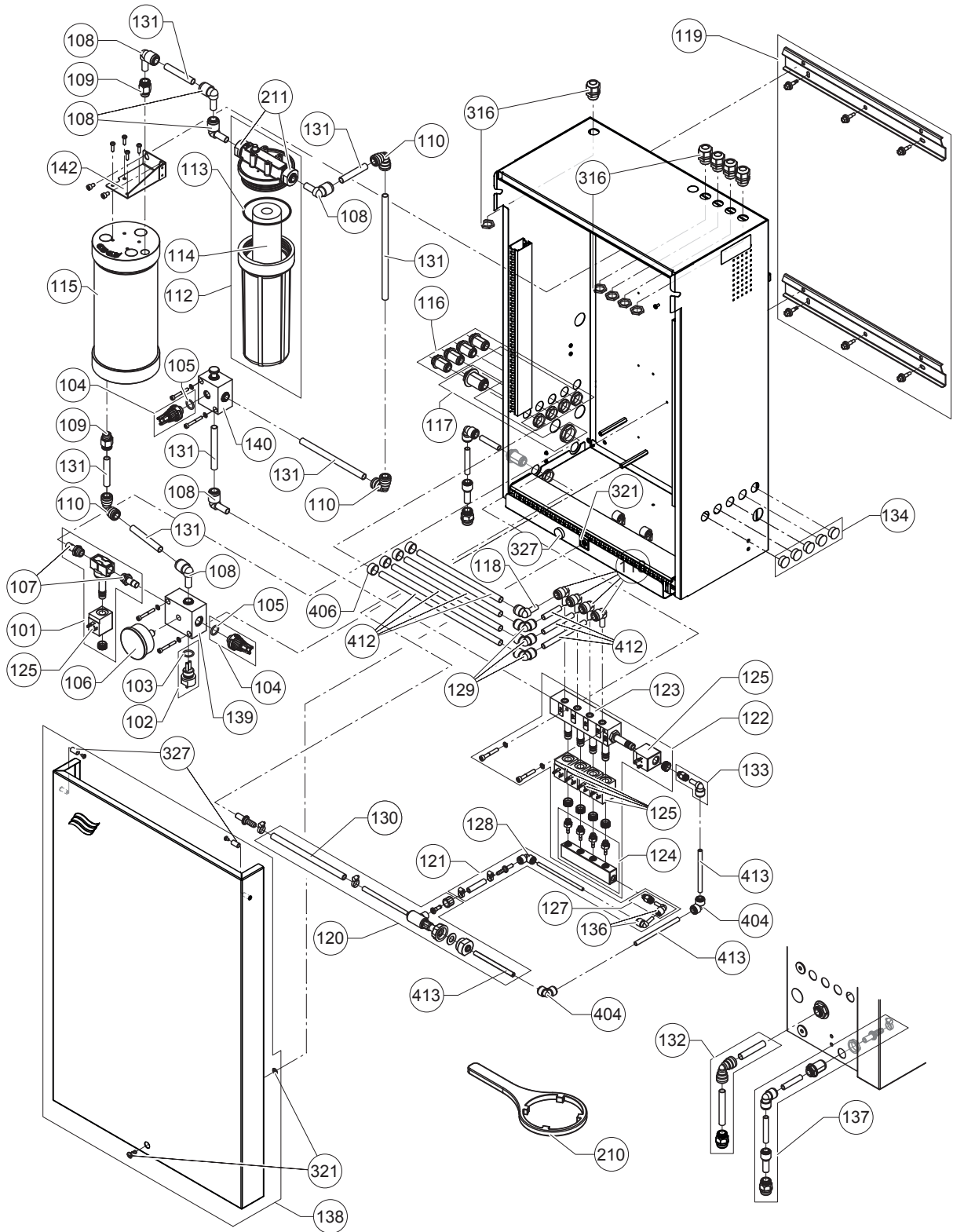

Zentraleinheit Typ B ohne Sterilfilter  
 Central unit Type B without sterile filter  
 Unité centrale Type B sans filtre stérile

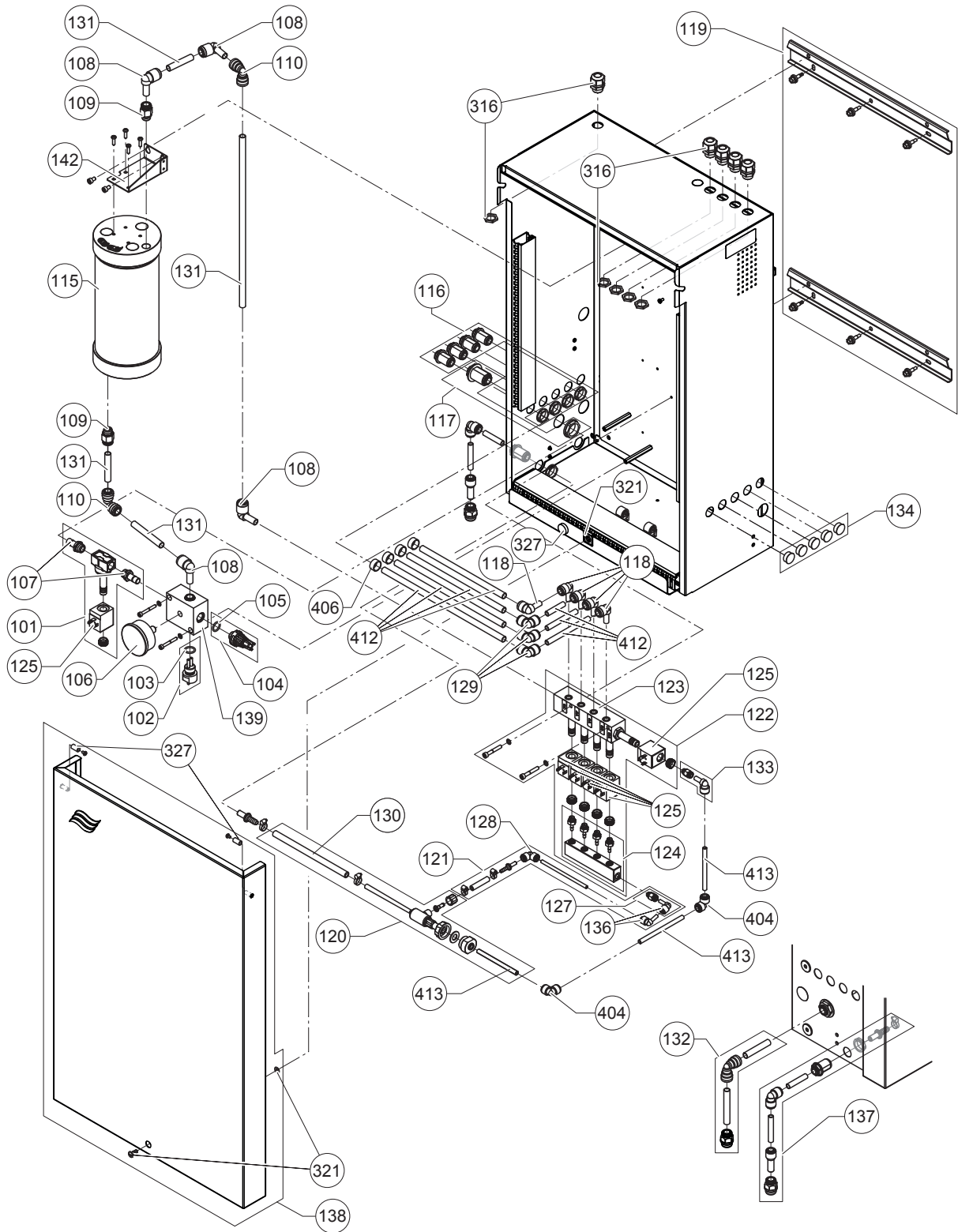

Steuereinheit  
Control unit  
Unité de commande

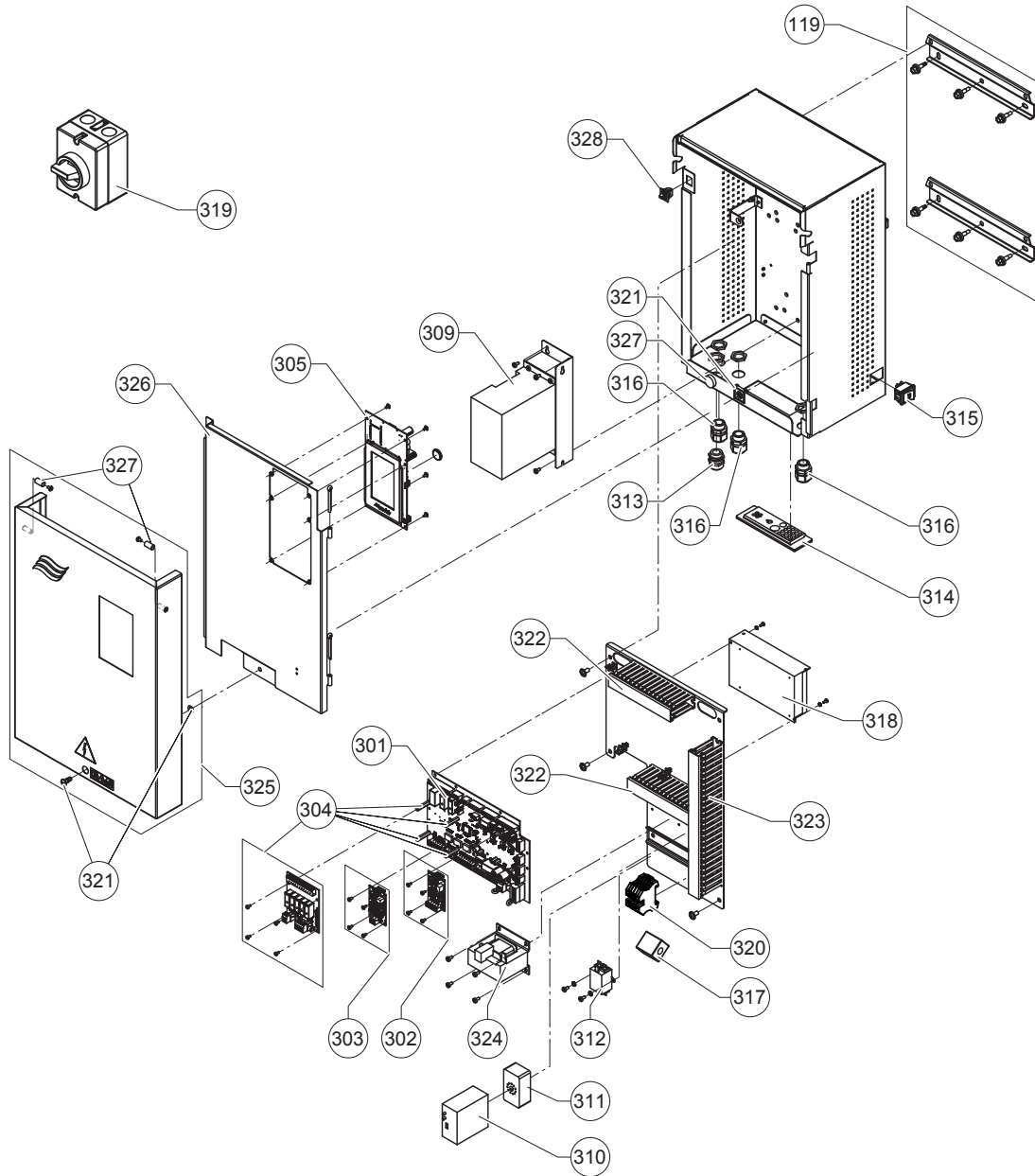

Düsensystem  
 Nozzle system  
 Système des buses

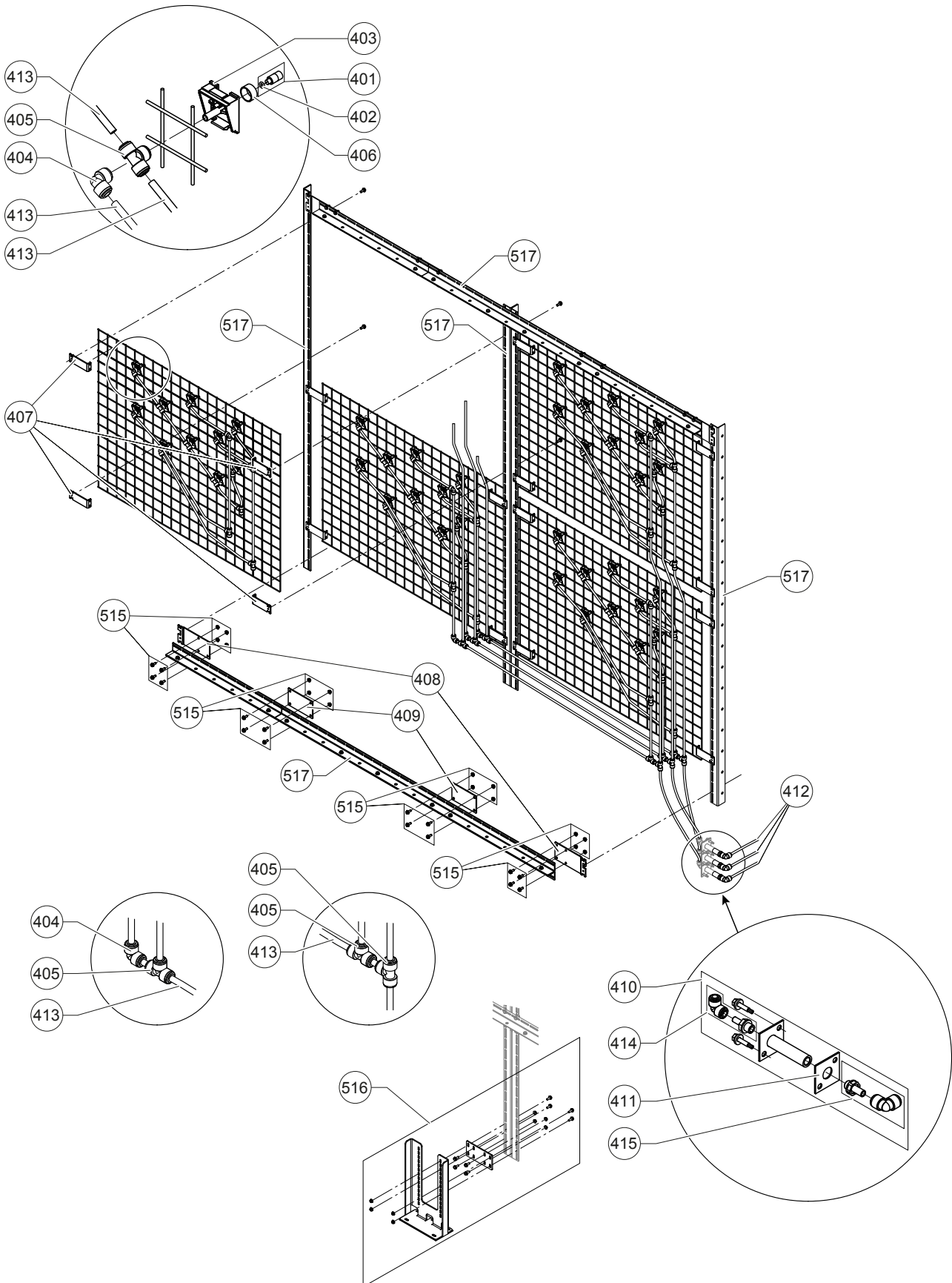

Nachverdunstereinheit  
Post evaporation unit  
Unité posthumidification

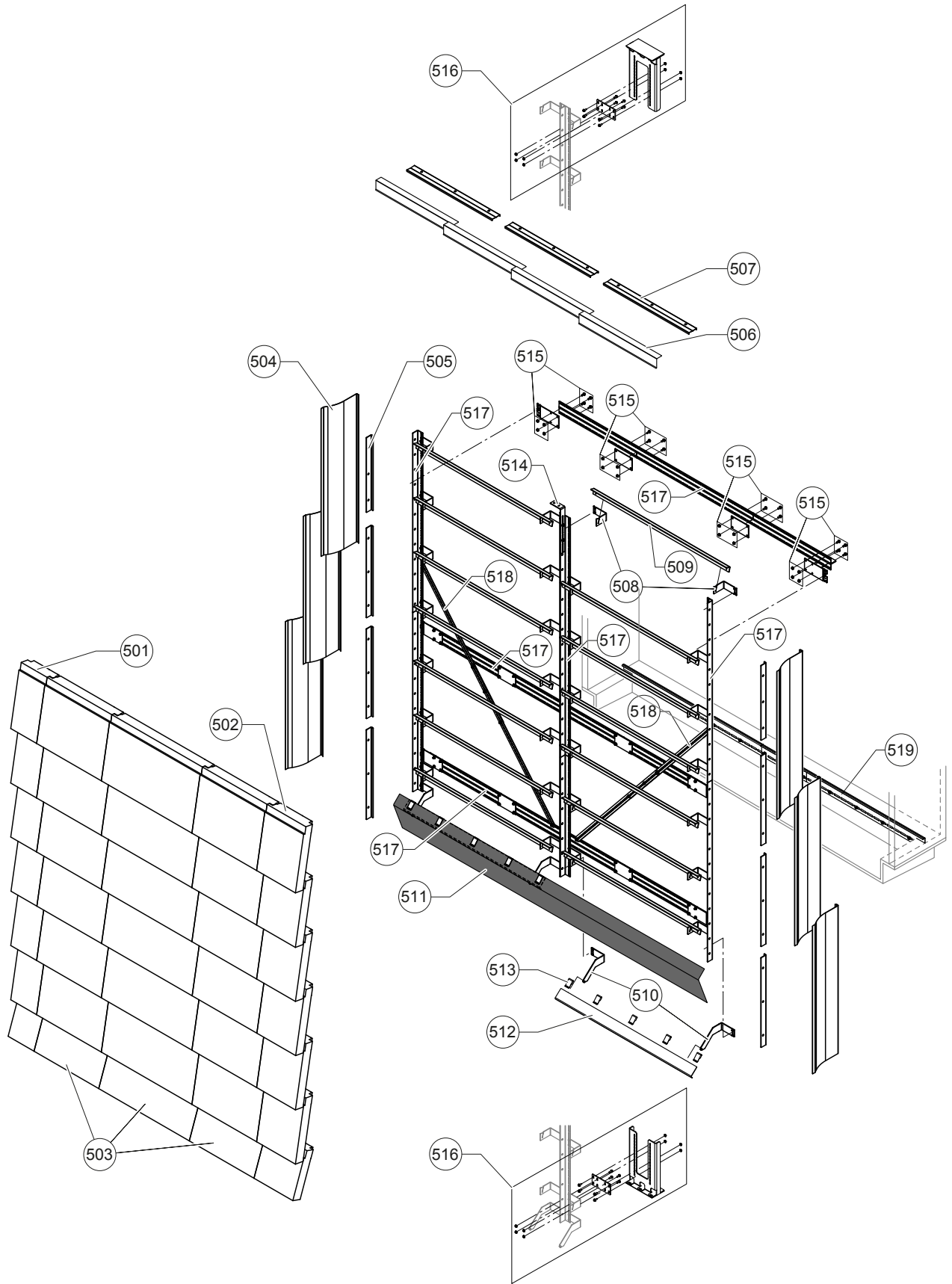

CONSULTING, SALES AND SERVICE:



CH94/0002.00

Condair Group AG  
Gwattstrasse 17, 8808 Pfäffikon SZ, Switzerland  
Phone: +41 55 416 61 11, Fax +41 55 588 00 07  
info@condair.com, www.condairgroup.com

