

INSTALLATION MANUAL

Steam generator
Condair **Omega**

Thank you for choosing Condair

Installation date (MM/DD/YYYY):

Commissioning date (MM/DD/YYYY):

Site:

Model:

Serial number:

Proprietary Notice

This document and the information disclosed herein are proprietary data of Condair Group AG. Neither this document, nor the information contained herein shall be reproduced, used, or disclosed to others without the written authorisation of Condair Group AG, except to the extent required for installation or maintenance of recipient's equipment.

Liability Notice

Condair Group AG does not accept any liability due to incorrect installation or operation of the equipment or due to the use of parts/components/equipment that are not authorised by Condair Group AG.

Copyright Notice

© Condair Group AG, All rights reserved.

Technical modifications reserved

Contents

1	Introduction	6
1.1	To the very beginning	6
1.2	Notes on the installation manual	6
2	For your safety	8
3	Product Overview	10
3.1	Models overview	10
3.2	Identification of the unit	11
3.3	Application overview Condair Omega steam generator	12
3.4	Versions of the Condair Omega steam generator	13
3.5	System / application overviews	13
3.5.1	Condair Omega with Omega control for steam shower application, temperature controlled operation	14
3.5.2	Condair Omega with Omega control for steam shower application, with constant steam operation	15
3.5.3	Condair Omega with Omega control for steam shower application, operation with external demand signal	16
3.5.4	Condair Omega with SPA control and equipment for steam bath application	17
3.5.5	Condair Omega with SPA control and equipment for steam bath application with optional bench heating	18
3.5.6	Condair Omega with SPA control and equipment for Caldarium application	19
3.5.7	Condair Omega with SPA control and equipment for Rasul application	20
3.5.8	Condair Omega 2 kg/h with SPA control and equipment for Bio sauna application	21
3.5.9	Condair Omega with SPA control for dual cabin application for small cabins (Fin sauna and steam bath without bench heating)	22
3.5.10	Condair Omega with SPA Control and Condair Delta SPA Control Box for dual cabin applications for medium size cabins	23
3.6	Options	24
3.7	Accessories steam generator	24
3.8	Accessories for SPA applications	24
4	Inspecting the delivery / Storage and Transportation	25
4.1	Delivery	25
4.1.1	Standard delivery	25
4.2	Inspecting the delivery	25
4.3	Storage and Transportation	26
5	Notes for the planning engineer	27
5.1	Selecting the unit version	27
5.1.1	Determination of the required steam capacity	27
5.1.2	Selecting the unit	28
5.2	Selecting the options an accessories	28

6	Mounting and installation work	29
6.1	Safety notes on mounting and installation work	29
6.2	Installation overview	30
6.3	Mounting the unit	32
6.3.1	Notes on locating the unit	32
6.3.2	Wall mounting	34
6.3.3	Floor mounting	36
6.3.4	Inspecting the installed unit	36
6.4	Steam installation	37
6.4.1	Overview steam installation	37
6.4.2	Positioning/mounting the steam distributor	38
6.4.3	Installing the steam and condensate lines	38
6.4.4	Common steam and condensate line errors	42
6.4.5	Inspecting the steam installation	43
6.5	Water installation	44
6.5.1	Overview water installation	44
6.5.2	Notes on water installation	46
6.5.3	Inspecting the water installation	47
6.6	Electric installation	48
6.6.1	Notes on electrical installation	48
6.6.2	Opening/Closing the Condair Omega and the Condair Delta SPA Control Box	49
6.6.3	Wiring diagrams	50
6.6.3.1	Wiring diagram Condair Omega with Omega control for steam shower application	50
6.6.3.2	Wiring diagram Condair Omega with SPA control for steam bath application	52
6.6.3.3	Wiring diagram Condair Omega with SPA control for steam bath application with optional bench heating	54
6.6.3.4	Wiring diagram Condair Omega with SPA control for Caldarium application with bench and wall heating	56
6.6.3.5	Wiring diagram Condair Omega with SPA control for Rasul application with bench and wall heating	58
6.6.3.6	Wiring diagram Condair Omega 2 kg/h with SPA control for bio sauna application, sauna heating controlled internally	60
6.6.3.7	Wiring diagram Condair Omega 8 kg/h with SPA control for dual cabin application (Fin sauna / Steam bath), sauna heating controlled internally	62
6.6.3.8	Wiring diagram Condair Omega 8 kg/h with SPA control for dual cabin application (Fin sauna / steam bath) with an externally powered sauna heater	64
6.6.4	Installation work external connections	66
6.6.4.1	Connection of switch "S1" and buttons "S2" to "S4"	66
6.6.4.2	Connection of the temperature sensor "A1" for monitoring the cabin temperature	67
6.6.4.3	Connection of the humidity sensor "A2"	68
6.6.4.4	Connection of the temperature sensor "A3" of the bench heating	68
6.6.4.5	Connection of the temperature sensor "A4" of the wall heating	69
6.6.4.6	Connection of the cabin over-temperature switch "A6"	69
6.6.4.7	Connection of the temperature sensors "A1" and "A7" for the temperature control of small cabins for dual cabin application	70
6.6.4.8	Connection of the temperature sensor "A8"	71
6.6.4.9	Connecting the signal cable of an external controller "A9"	71
6.6.4.10	Connection of the demand signal "A10" for controlling the heating of an externally powered sauna heater	72
6.6.4.11	Connection of the On/Off button "B2"	72
6.6.4.12	Connection of fragrance pumps "M1" and "M2" (230 VAC)	73
6.6.4.13	Connecting the cabin light "E1" and "E2"	73

6.6.4.14	Connection of color light "E3" for the sauna cabin for dual cabin application of small cabins	74
6.6.4.15	Connection of the fans "M3" and "M4"	75
6.6.4.16	Connection of the optional bench heating for steam bath application	76
6.6.4.17	Connection of the bench heating and the wall heating for caldarium and Rasul application	77
6.6.4.18	Connection of the sauna heater for Bio sauna for single cabin application and for Fin sauna for dual cabin application	78
6.6.4.19	Connection of the relays "Rel 8" and "Rel 9"	79
6.6.4.20	Connection of the fault output "Err. Out"	80
6.6.4.21	Connection of external safety chain	80
6.6.4.22	Connecting the external SPA display(s) (accessory)	81
6.6.4.23	Power supplies	85
6.6.5	Performance data / Fuses "F5" power supply	91
6.6.6	Maximum power consumption accessories for Condair Omega with SPA Control	91
6.6.7	Connection data accessories	92
6.6.8	Inspecting the electrical installation	93
7	Appendix	94
7.1	Unit dimensions	94
7.1.1	Unit dimensions unit "Small" (Condair Omega 2...8)	94
7.1.2	Unit dimensions unit "Medium" (Condair Omega 12...20)	95

1 Introduction

1.1 To the very beginning

We thank you for having purchased the **Condair Omega steam generator**.

The Condair Omega steam generator incorporates the latest technical advances and meets all recognized safety standards. Nevertheless, improper use of the Condair Omega steam generator may result in danger to the user or third parties and/or damage to property.

To ensure a safe, proper, and economical operation of the Condair Omega steam generator, please observe and comply with all information and safety instructions contained in the present documentation as well as in the separate documentations of the components installed in the humidification system.

If you have questions after reading this documentation, please contact your Condair representative. They will be glad to assist you.

1.2 Notes on the installation manual

Limitation

The subject of this installation manual is the Condair Omega steam generator in its different versions. The various options and accessories are only described insofar as is necessary for proper operation of the equipment. Further information on options and accessories can be obtained in their respective instructions.

This installation manual is restricted to the **installation** of the Condair Omega steam generator and is meant for **well trained specialists being sufficiently qualified for their respective work**.

This installation manual is supplemented by various separate items of documentation (operation manual, spare parts list, etc.), which are included in the delivery as well. Where necessary, appropriate cross-references are made to these publications in the installation manual.

Symbols used in this manual



CAUTION!

The catchword "CAUTION" used in conjunction with the general caution symbol designates notes in this installation manual that, if neglected, may cause **damage and/or malfunction of the unit or damage to property**.



WARNING!

The catchword "WARNING" used in conjunction with the general caution symbol designates safety and danger notes in this installation manual that, if neglected, may cause **injury to persons**.



DANGER!

The catchword "DANGER" used in conjunction with the general caution symbol designates safety and danger notes in this installation manual that, if neglected, may lead to **severe injury or even death of persons**.

Safekeeping

Please safeguard this installation manual in a safe place, where it can be immediately accessed. If the equipment changes hands, the documentation must be passed on to the new operator.

If the documentation gets misplaced, please contact your Condair representative.

Language versions

This installation manual is available in other languages. Please contact your Condair representative for information.

2 For your safety

General

Every person, who is in charge of the installation work on the Condair Omega must have read and understood this installation manual and the Condair Omega operation manual before carrying out any work. Knowing and understanding the contents of the installation manual and the operation manual is a basic requirement for protecting personnel against any kind of danger, to prevent faulty operation, and to operate the unit safely and correctly.

All icons, signs and markings applied to the Condair Omega must be observed and kept in readable state.

Qualification of personnel

All installation work described in this installation manual **may only be carried out by specialists who are well trained and adequately qualified and are authorised by the customer.**

For safety and warranty reasons any action beyond the scope of this manual must be carried out only by qualified personnel authorised by Condair.

It is assumed that all persons working with the Condair Omega are familiar and comply with the appropriate regulations on work safety and the prevention of accidents.

Intended use

The Condair Omega steam generator is intended exclusively for the generation of steam for steam showers, steam baths, caldariums and Rasul as well as for dual cabin applications in the SPA field within the specified operating conditions. Any other type of application, without the written consent of Condair, is considered as not conforming with the intended purpose and may lead to the Condair Omega becoming dangerous and will void any warranty.

Operation of the equipment in the intended manner requires **that all the information contained in this installation and operation manual are observed (in particular the safety instructions).**

Danger that may arise from the Condair Omega



DANGER!
Danger of electric shock!

The Condair Omega is mains powered. Live parts may be exposed when the unit is open. Touching live parts may cause severe injury or danger to life.

Prevention: The Condair Omega must be connected to the mains only after all mounting and installation work has been completed, all installations have been checked for correct workmanship and the unit is closed and properly locked.

Preventing unsafe operation

All persons working with the Condair Omega are obliged to report any alterations to the unit that may affect safety to the owner without delay and to **secure the Condair Omega against accidental power-up.**

Prohibited modifications to the unit

No modifications must be undertaken on the Condair Omega without the express written consent of Condair.

For the replacement of defective components use exclusively **original accessories and spare parts** available from your Condair representative.

3 Product Overview

3.1 Models overview

Steam generators Condair Omega are available in **two unit sizes** with **different heating voltages** and **steam capacities ranging from 2 kg/h up to a maximum of 20 kg/h**.

Model Condair Omega	Unit size		Max. steam capacity in kg/h	P _N max. in kW	Heating voltage
	Small	Medium			
2	x		2	2.0	230 V/1~/50...60 Hz
4	x		4	3.5	
6	x		6	5.0	
8	x		8	6.5	
6	x		6	5.0	400 V/3~/50...60 Hz
8	x		8	6.5	
12		x	12	9.5	
16		x	16	12.5	
20		x	20	15.5	

Key model designation

Example:
Condair Omega 8

Product designation _____

Max. steam capacity in kg/h _____

3.2 Identification of the unit

The identification of the unit is found on the rating plate:

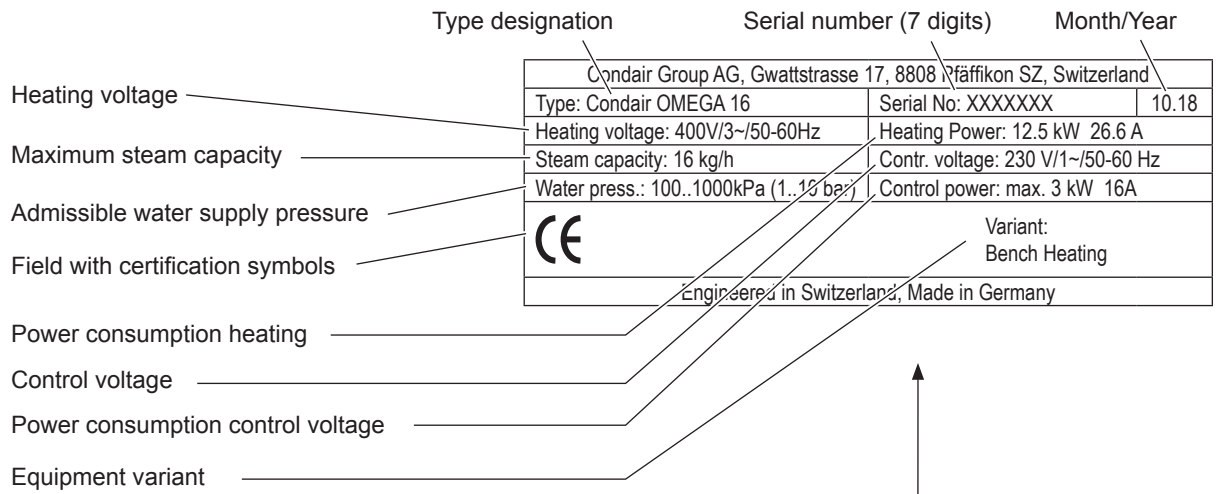

Fig. 1: Location of the specification label

3.3 Application overview Condair Omega steam generator

The Condair Omega steam generator is available in different versions for different applications in the SPA sector.









Application	Description	Control cabin climate	Accessories										
			Light		Ventilation		Fragrance		Shower	Heating (Optional)		Additional relays	
			Light 1 (Cleaning or color light)	Light 2 (Cleaning or color light)	Fan 1 (Supply or exhaust fan)	Fan 2 (Supply or exhaust fan)	Fragrance 1 (Pump 1)	Fragrance 2 (Pump 2)	Shower (Pumpe 2)	Bench heating (Rel 8)	Wall heating (Rel 9)	Music, ... (Rel 8)	Music, ... (Rel 9)
Steam shower	Steam cabin with steam	Temperature control up to 50 °C	-	-	-	-	-	-	-	-	-	-	-
Steam bath	Steam bath cabin supplied with steam from a steam generator. The humidity in the steam cabin is almost 100%. The heat is generated by the supplied steam and the optional bench heating in the cabin.	Temperature control up to 50 °C	x	x	x	x	x	x	-	x	-	(x)	x
Caldarium	Steam cabin supplied with steam from a steam generator. The humidity in the cabin is almost 70%. The heat is generated by the wall heating and the bench heating in the cabin.	Humidity control up to 80% rh	x	x	x	x	x	x	-	x	x	-	-
Rasul	Steam cabin supplied with steam from a steam generator. The humidity in the cabin is almost 70%. The heat is generated by the wall heating and the bench heating in the cabin.	Humidity control up to 80% rh	x	x	x	x	x	-	x	x	x	-	-
Fin sauna	Sauna cabin with sauna heater. The heat in the sauna cabin is generated by the sauna heater.	Temperature control up to 110 °C	x	x	x	x	-	-	-	-	-	x	x
Bio sauna	Sauna cabin with sauna heater and steam. The heat in the sauna cabin is generated by the sauna heater. The steam is generated via the Condair Omega.	Temperature and humidity control	x	x	x	x	x	x	-	-	-	x	x
Dual cabin (small)	Dual cabin with steam bath and Fin sauna. Both cabins can be controlled via a single SPA Display.	Steam bath Temperature control up to 50 °C	x	x	x	-	x	x	-	-	-	-	x
		Fin sauna Temperature control up to 110 °C		x	-	x	-	-	-	-	-		
Dual cabin (medium large)	Dual cabin with two arbitrarily selectable cabin types. Both cabins can be controlled via a single SPA Display.	Cabin 1	Any single cabin, see above (e.g. Steam bath)										
		Cabin 2	Any single cabin, see above (e.g. Fin sauna)										







3.4 Versions of the Condair Omega steam generator

Application / Cabin type	Hardware variant Condair Omega	Steam generation / Steam generator	Sauna heating
Steam shower	Condair Omega with Omega control	Condair Omega 2-20 kg/h	—
Steam bath without bench heating	Condair Omega with SPA control with standard equipment	Condair Omega 2-20 kg/h	—
Steam bath with optional bench heating	Condair Omega with SPA control with equipment for bench heating	Condair Omega 2-20 kg/h	—
Caldarium	Condair Omega with SPA control with equipment for bench and wall heating	Condair Omega 2-20 kg/h	—
Rasul	Condair Omega with SPA control with equipment for bench and wall heating	Condair Omega 2-20 kg/h	—
Bio sauna	Condair Omega 2 kg/h with SPA control with equipment for Fin sauna	Condair Omega 2 kg/h	Third-party sauna heater (heat power is switched directly via SPA Control)
Dual cabin small (steam bath & sauna)	Condair Omega 8 kg/h with SPA Control with equipment for Fin sauna	Condair Omega 8 kg/h	Third-party sauna heater (heat power is switched directly via SPA Control)
Dual cabin medium size		Two single cabins can be combined as desired. See the corresponding settings in the list above	

3.5 System / application overviews

The following chapters contain the corresponding system / application overviews. The following symbols are used in these system overviews.

	Fan 1 / 2 (Control of supply or exhaust fan)
	Light 1 / 2 (Control of cleaning or color light)
	Heating 1 / 2 (e.g. control of sauna heater, bench heating, etc.)
	Fragrance 1 / 2 (Control of fragrance pump 1 / 2)
	Temperature sensor (Measurement of cabin temperature, bench temperature, etc.)
	Humidity sensor (Measurement of cabin humidity)
	Door contact
	On/Off button SPA operation

	Steam (Steam generated by steam generator)
	Shower (Control of the cabin shower for Rasul application)
	Speaker (Control of music)
	Power supply
	Water supply steam generator
	Water drain steam generator
	Externes Anforderungssignal

3.5.1 Condair Omega with Omega control for steam shower application, temperature controlled operation

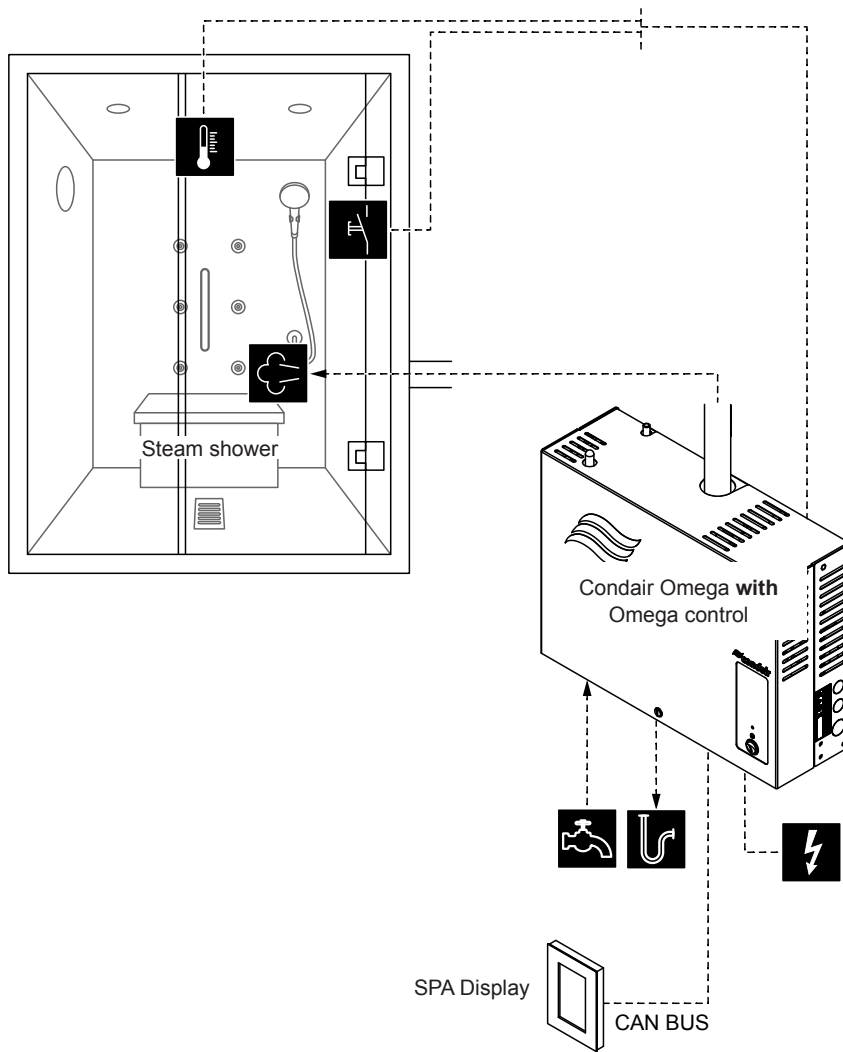

Fig. 2: Condair Omega with Omega control for steam shower application, temperature controlled operation

3.5.2 Condair Omega with Omega control for steam shower application, with constant steam operation

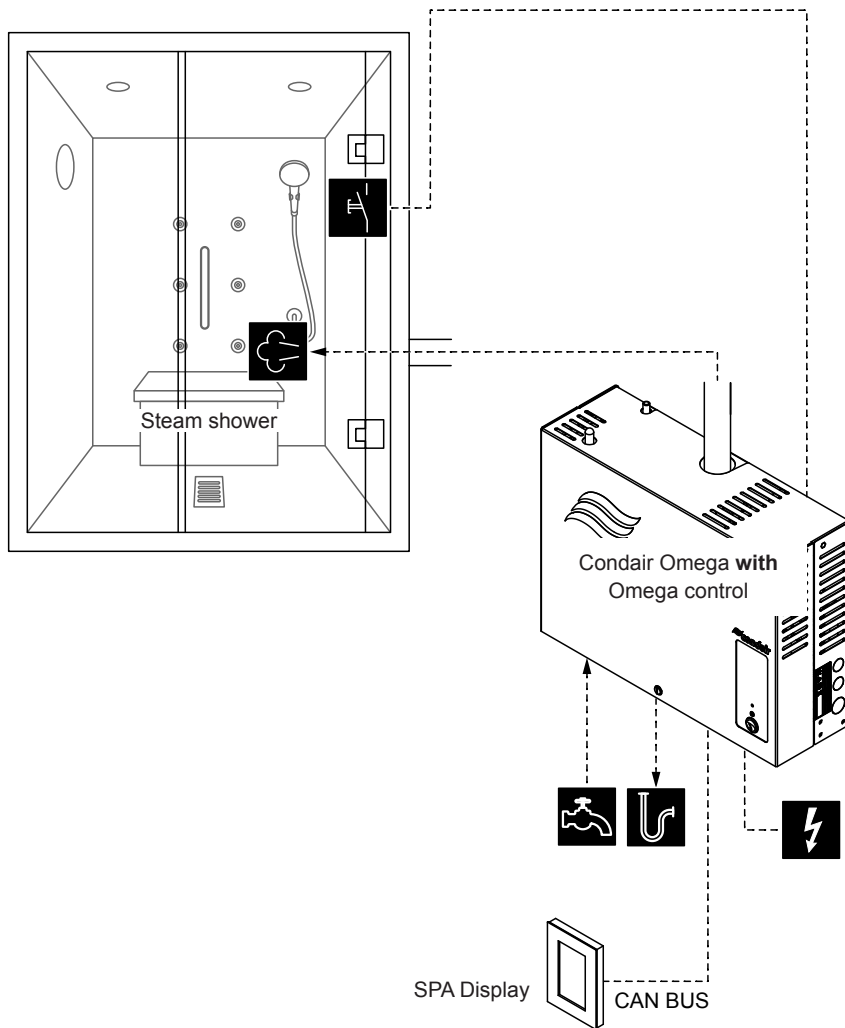

Fig. 3: Condair Omega with Omega control for steam shower application, with constant steam operation

3.5.3 Condair Omega with Omega control for steam shower application, operation with external demand signal

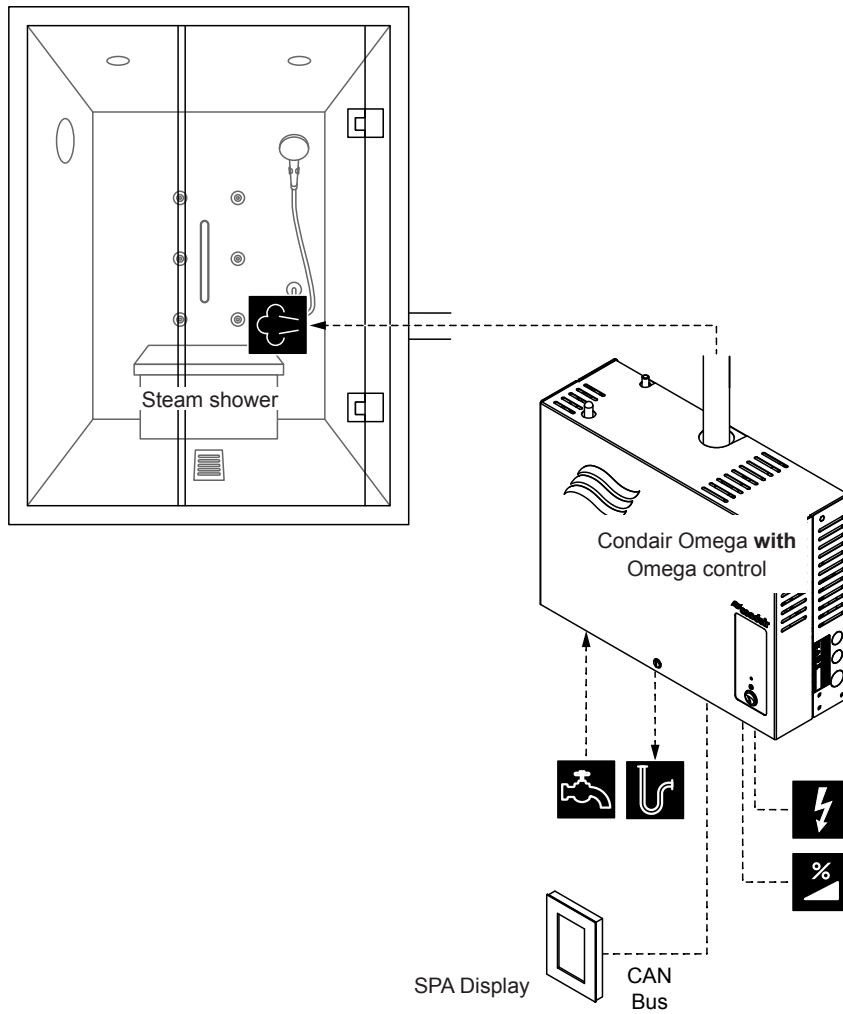

Fig. 4: Condair Omega with Omega control for steam shower application, operation with external demand signal

3.5.4 Condair Omega with SPA control and equipment for steam bath application

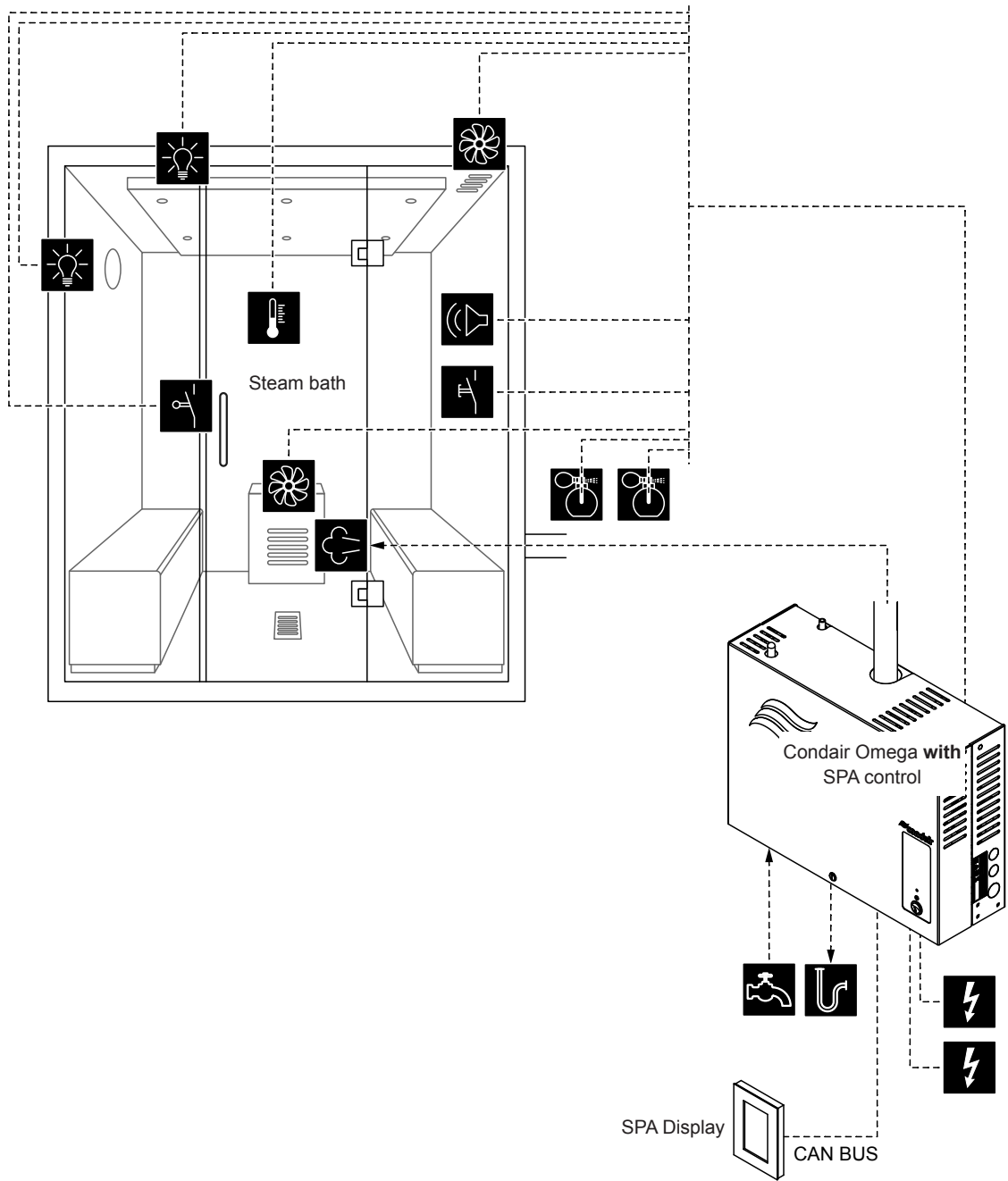

Fig. 5: Condair Omega with SPA control and equipment for steam bath application

3.5.5 Condair Omega with SPA control and equipment for steam bath application with optional bench heating

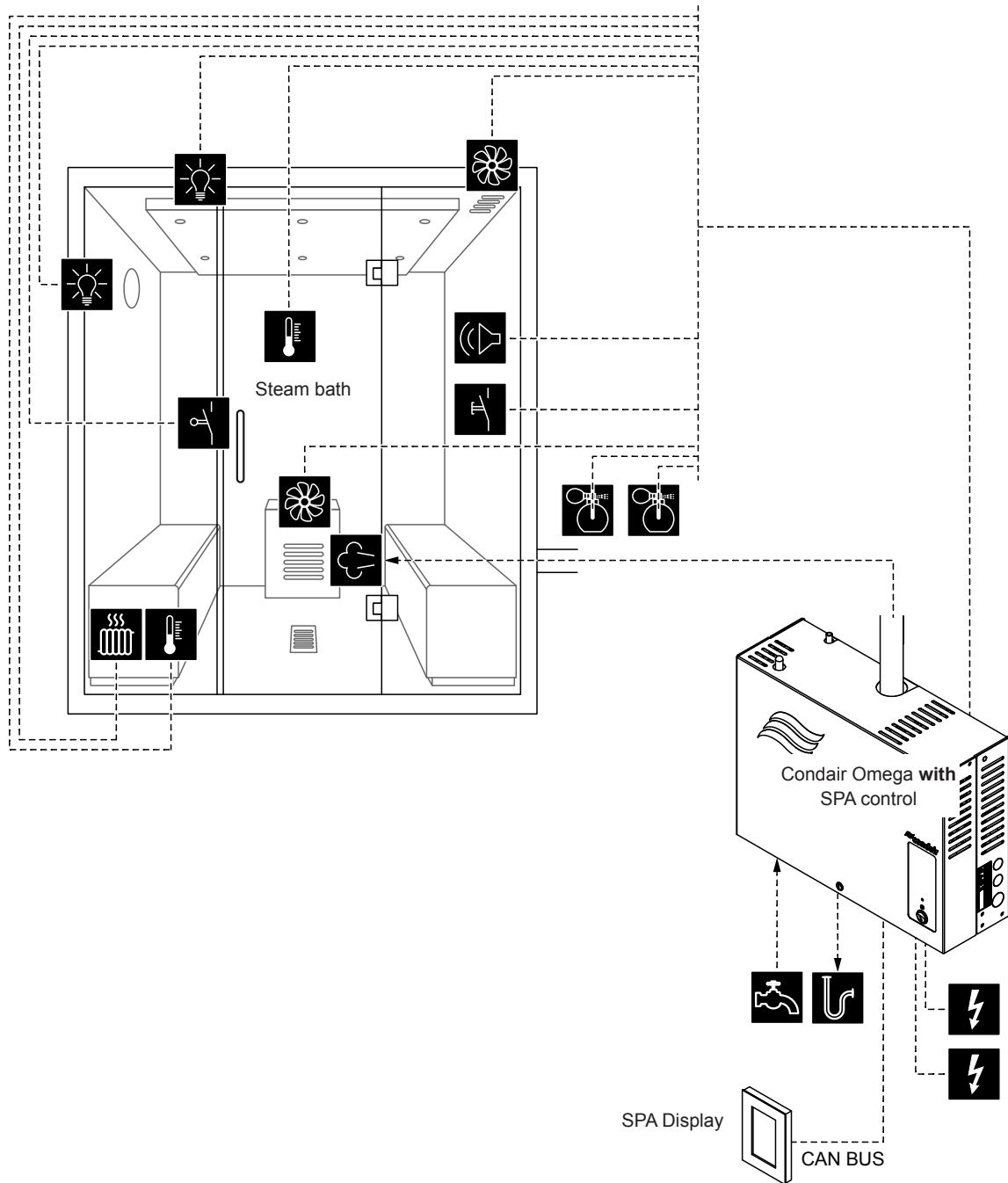

Fig. 6: Condair Omega with SPA control and equipment for steam bath application with optional bench heating

3.5.6 Condair Omega with SPA control and equipment for Caldarium application

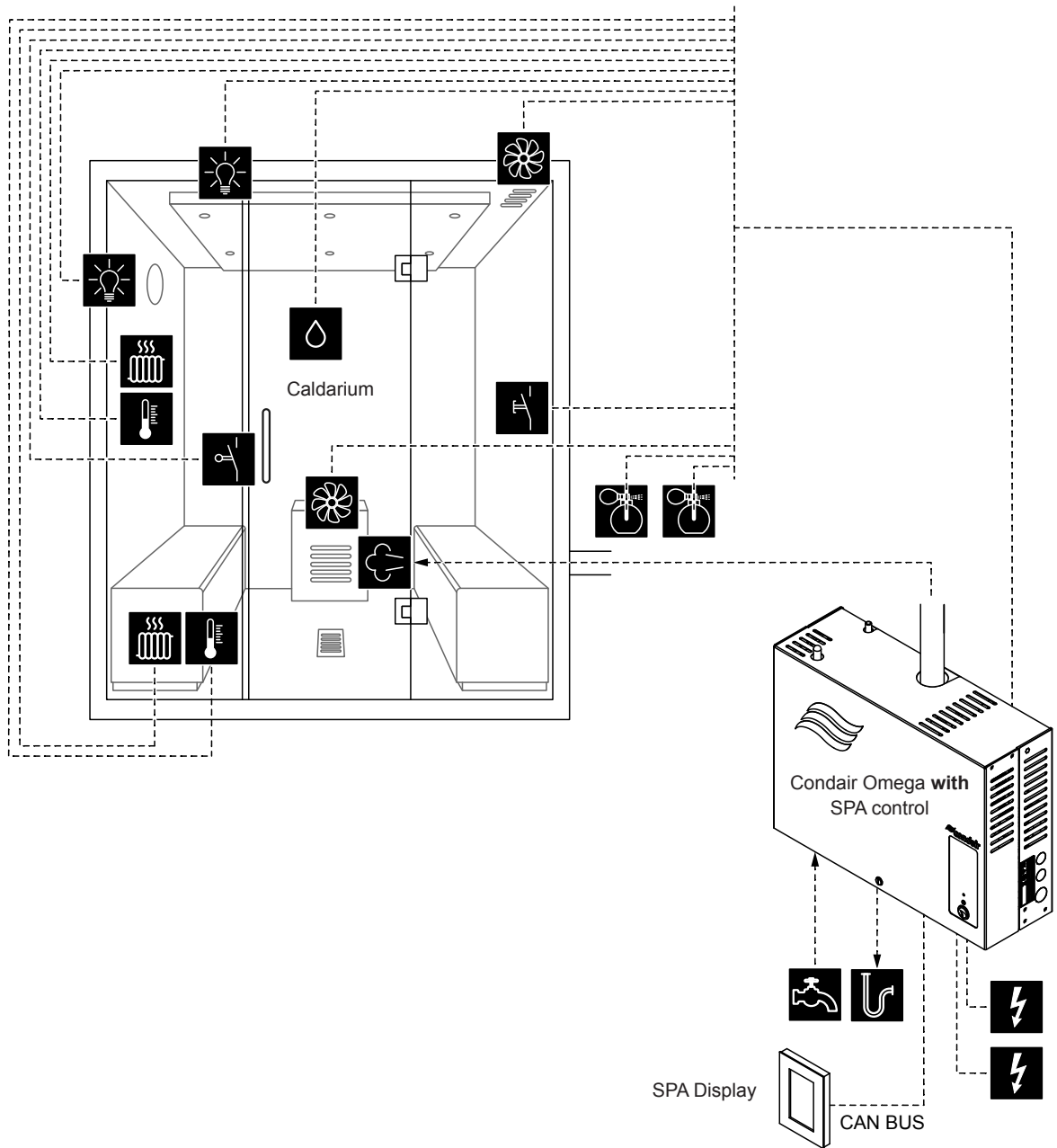

Fig. 7: Condair Omega with SPA control and equipment for Caldarium application

3.5.7 Condair Omega with SPA control and equipment for Rasul application

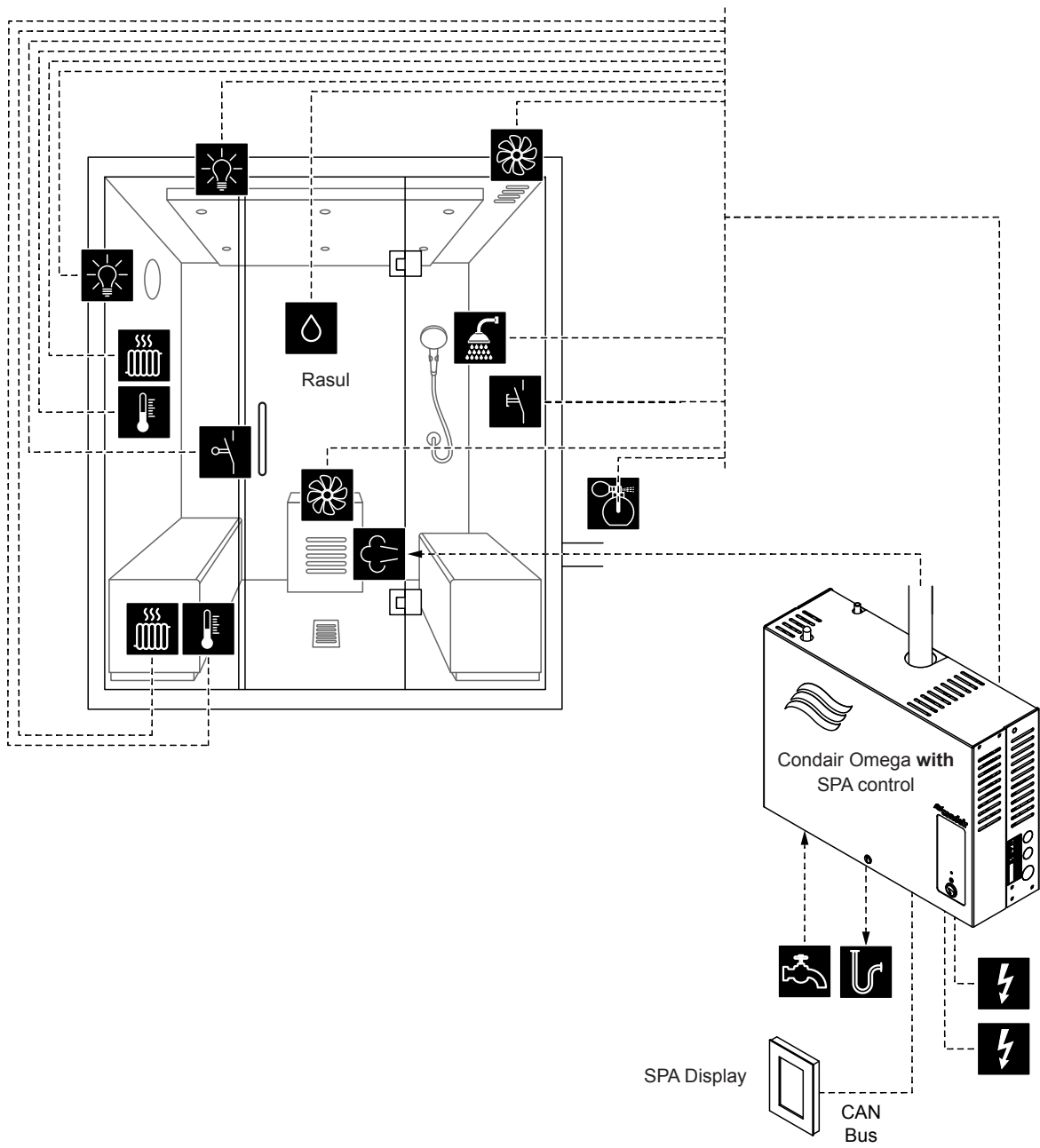

Fig. 8: Condair Omega with SPA control and equipment for Rasul application

3.5.8 Condair Omega 2 kg/h with SPA control and equipment for Bio sauna application

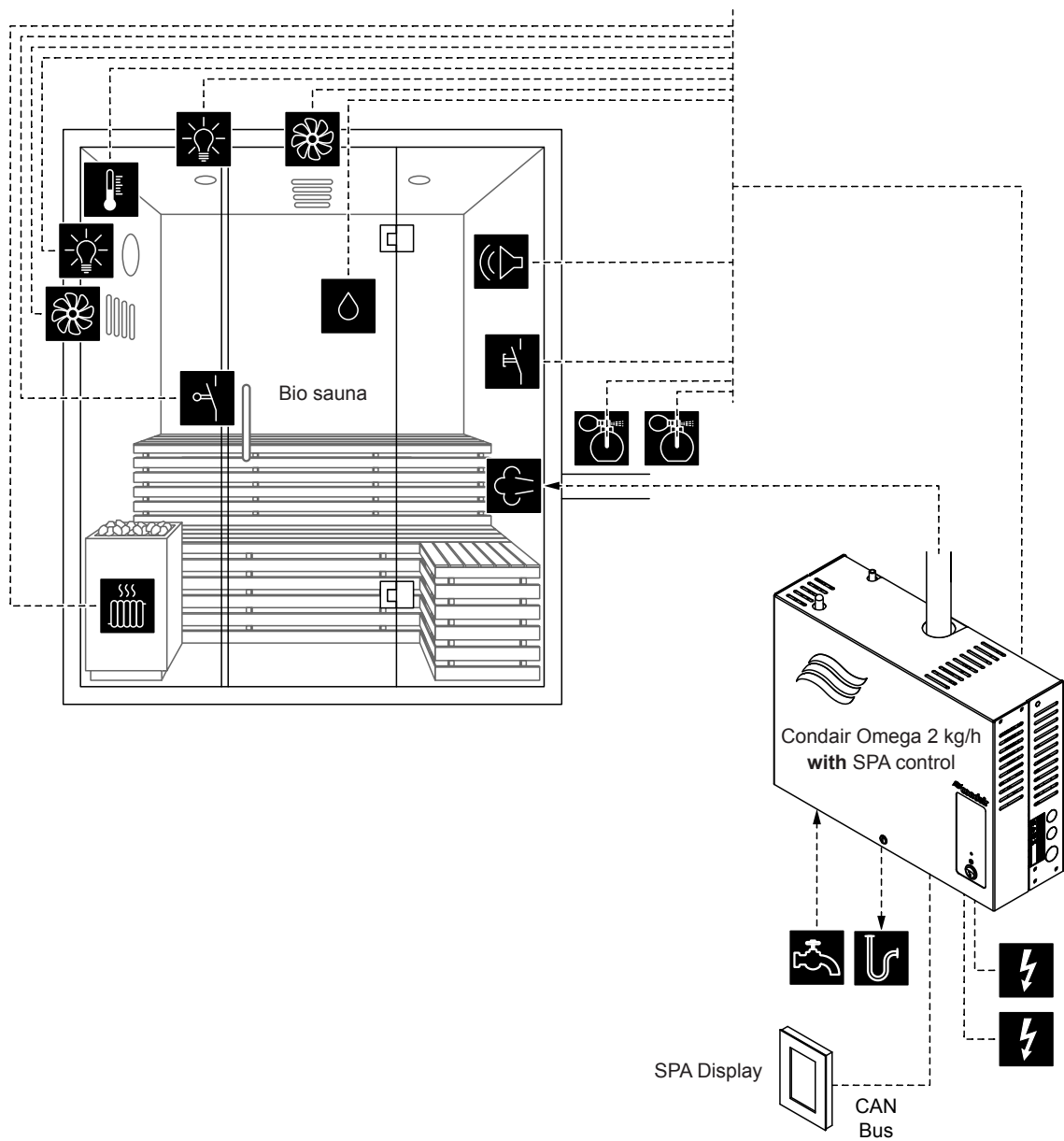

Fig. 9: Condair Omega 2 kg/h with SPA control and equipment for Bio sauna application

3.5.9 Condair Omega with SPA control for dual cabin application for small cabins (Fin sauna and steam bath without bench heating)

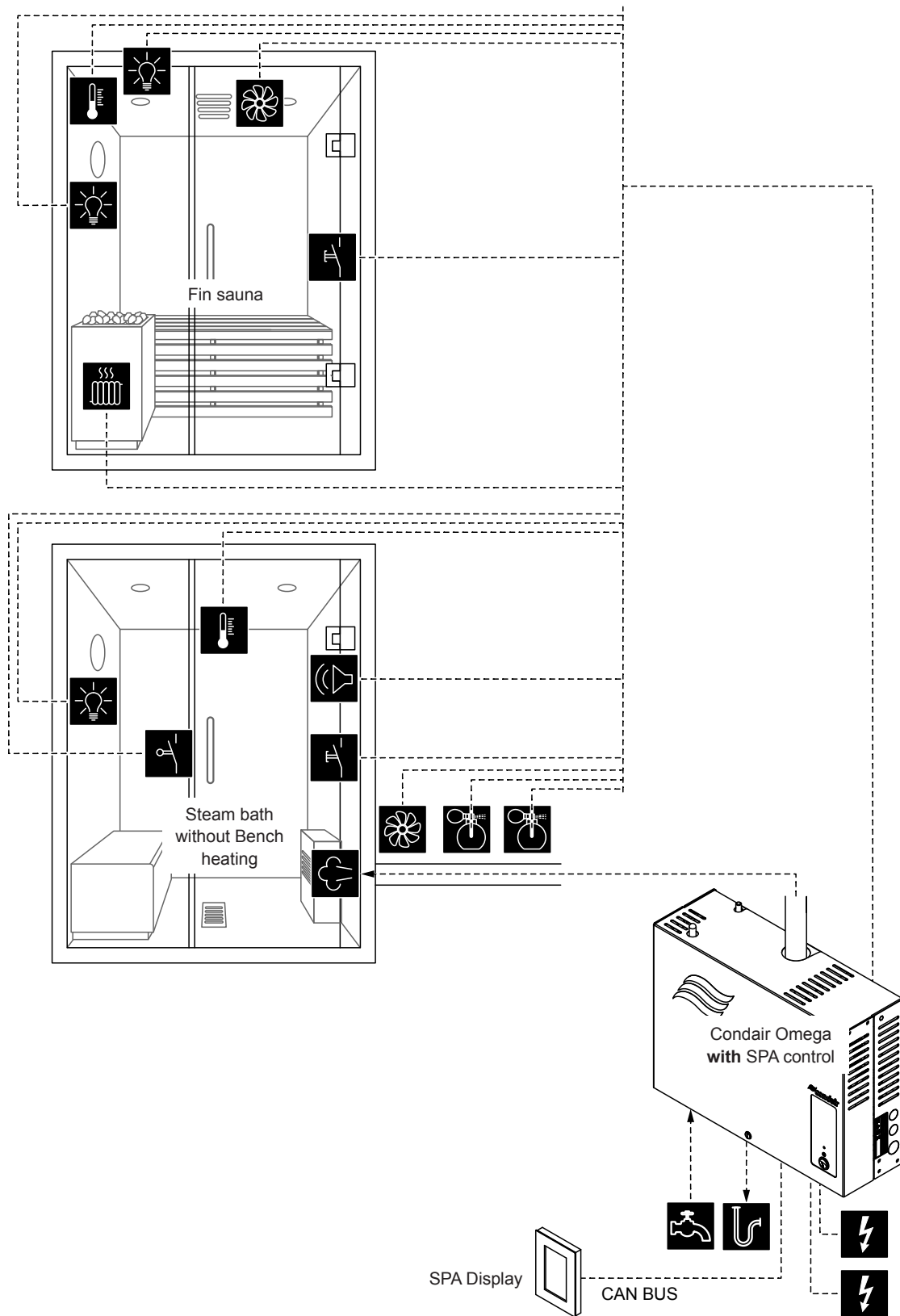

Fig. 10: Condair Omega with SPA control for dual cabin application for small cabins (Fin sauna and steam bath without bench heating)

3.5.10 Condair Omega with SPA Control and Condair Delta SPA Control Box for dual cabin applications for medium size cabins

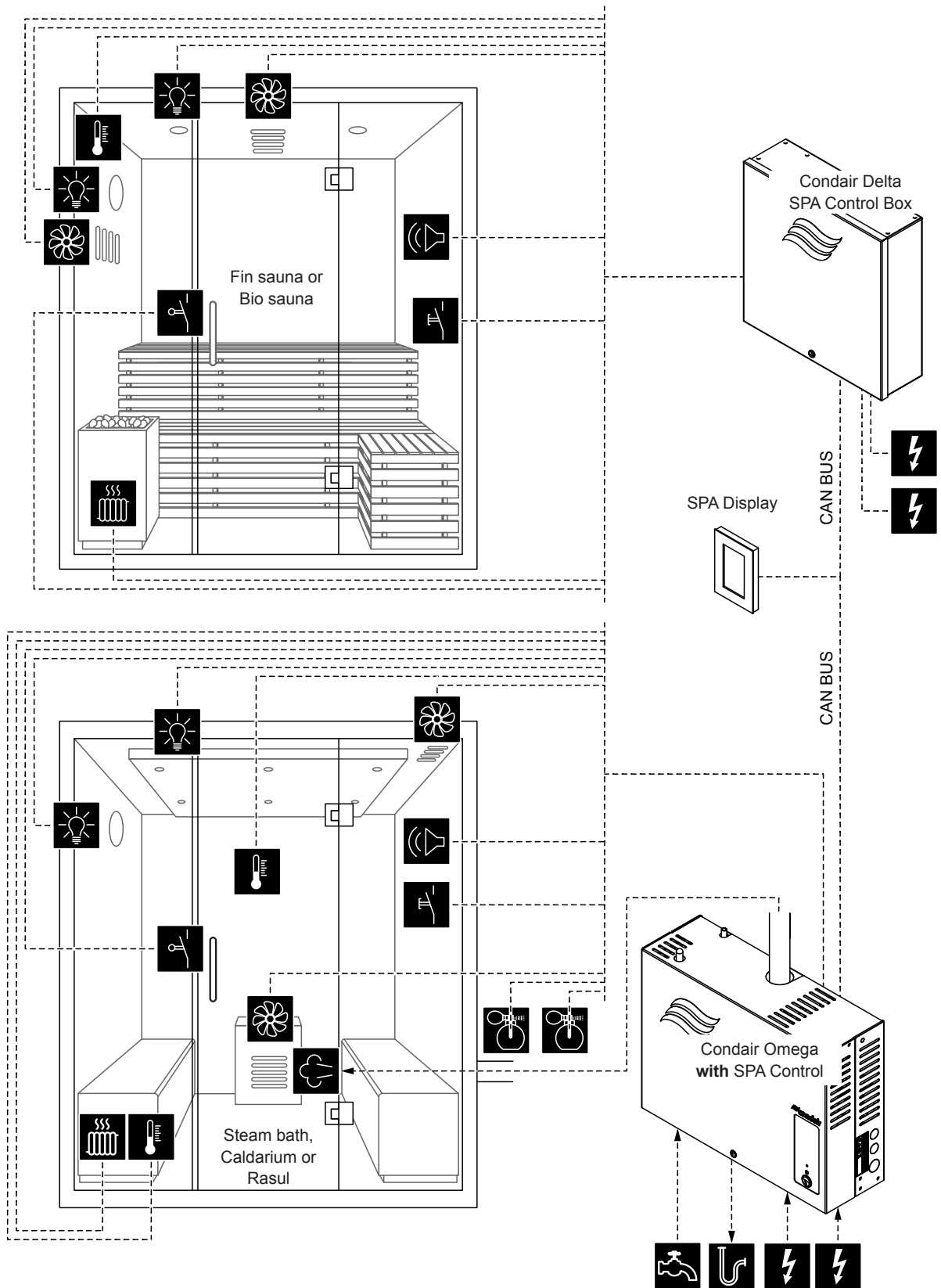

Fig. 11: Condair Omega with SPA Control and Condair Delta SPA Control Box for dual cabin applications for medium size cabins

3.6 Options

	Condair Omega						
	2	4	6	8	12	16	20
Touch-Display internal	1x						

3.7 Accessories steam generator

	Condair Omega						
	2	4	6	8	12	16	20
Filter valve	1x Z261						
Filter cartridge	1x Filter cartridge Size S				1x Filter cartridge Size L		
Mounting station	1x						
Touch-Display external on-wall	1x						
Touch-Display external in-wall	1x						

3.8 Accessories for SPA applications

A separate product documentation is available for accessories for SPA applications. Please contact your Condair representative.

4 Inspecting the delivery / Storage and Transportation

4.1 Delivery

4.1.1 Standard delivery

The standard delivery includes:

- Steam generator Condair Omega including fixing set, installation manual (this document) and operation manual (this document) and spare parts list, packaged in cardboard box.

Unit type	Dimensions packaging (L x W x D)	Transport weight
Condair Omega 2...8	555 mm x 465 mm x 250 mm	11.8 kg
Condair Omega 12..20	555 mm x 465 mm x 370 mm	15.8 kg

- Ordered options with operating instructions according [chapter 3.6](#), packed separately.
- Ordered accessories with operating instructions according [chapter 3.7](#) and [chapter 3.8](#), packed separately.

4.2 Inspecting the delivery

After receiving:

- Inspect shipping boxes for damage.
Any damages of the shipping boxes must be reported to the shipping company without delay.
- Check packing slip to ensure all parts has been delivered.
All material shortages are to be reported to your Condair supplier within 48 hours after receipt of the goods. Condair Group AG assumes no responsibility for any material shortages beyond this period.
- Unpack the parts/components and check for any damage.
If parts/components are damaged, notify the shipping company immediately.
- Check whether the components are suitable for installation on your site according to the unit data stated on the rating plate.

4.3 Storage and Transportation

Storing

Until installation store the Condair Omega in its original packaging in a protected area meeting the following requirements:

- Room temperature: 5 ... 40 °C
- Room humidity: 10 ... 75 %rh

Transportation

For optimum protection always transport the unit and components in their original packaging and use appropriate lifting/transporting devices.



WARNING!

It is the customer's responsibility to ensure that operators are trained in handling heavy goods and that the operators comply with the appropriate regulations on work safety and the prevention of accidents.

Packaging

Keep the original packaging of the components for later use.

In case you wish to dispose of the packaging, observe the local regulations on waste disposal. Please recycle packaging where possible.

5 Notes for the planning engineer

5.1 Selecting the unit version

To select the unit version the following planning steps are required:

1. Determining the required maximum steam capacity according [chapter 5.1.1](#).
2. Selecting the unit version from the table in [chapter 5.1.2](#).

5.1.1 Determination of the required steam capacity

The steam capacity required for a particular steam bath can be determined with the following table:

Cabin size	Required steam capacity	
	Plastic cabin	brick lined cabin
2 m ³	2 kg/h	6 kg/h
4 m ³	4 kg/h	8 kg/h
6 m ³	6 kg/h	10 kg/h
8 m ³	8 kg/h	12 kg/h
12 m ³	12 kg/h	16 kg/h
16 m ³	16 kg/h	20 kg/h
20 m ³	20 kg/h	24 kg/h

Important notes:

- The determined steam capacity based on the above table does not consider any steam loss (e.g. due to condensation in the steam hoses and the steam distributors), any heat loss of the unit as well as any absorption or release of humidity of materials located in the steam bath/steam shower being humidified.

In addition, the calculated steam capacity does not consider any losses caused by the draining rate depending on the water quality.

The total amount of losses depends on the entire system and must be taken into consideration when determining the required steam capacity. If you have any questions regarding the calculation of the steam capacity please contact your Condair representative.

5.1.2 Selecting the unit

Model Condair Omega	Unit Size		Max. steam capacity in kg/h	Heating voltage
	Small	Medium		
2	x		2	230 V/1~/50...60 Hz
4	x		4	
6	x		6	
8	x		8	
6	x		6	400 V/3~/50...60 Hz
8	x		8	
12		x	12	
16		x	16	
20		x	20	

5.2 Selecting the options and accessories

For selecting the options and accessories see [chapter 3.6](#), [chapter 3.7](#) and [chapter 3.8](#).

6 Mounting and installation work

6.1 Safety notes on mounting and installation work

Qualification of personnel

All mounting and installation work must be carried out only by **well qualified specialists authorised by the owner**. It is the owner's responsibility to verify proper qualification of the personnel.

General notes

Strictly observe and comply with all information given in the present installation manual regarding the mounting of the unit and the installation of water, steam and electricity.

Observe and comply with all local regulations dealing with water, steam and electrical installations.

Safety

Some installation work requires removal of the unit covers. Please note the following:



DANGER!
Danger of electric shock!

The Condair Omega is mains powered. Live parts may be exposed when the unit is open. Touching live parts may cause severe injury or danger to life.

Prevention: The Condair Omega must be connected to the mains only after all mounting and installation work has been completed, all installations have been checked for correct workmanship and the unit is closed and properly locked.



CAUTION!

The electronic components inside the steam generator are very sensitive to electrostatic discharge.

Prevention: To protect these components against damage caused by electrostatic discharge (ESD protection) appropriate measures must be taken when the unit is open for installation work.



VORSICHT!

The Condair Omega with SPA control is not splash-proof (IPX4).

Prevention: The Condair Omega with SPA control must therefore not be used for prefabricated sauna cabins.

6.2 Installation overview

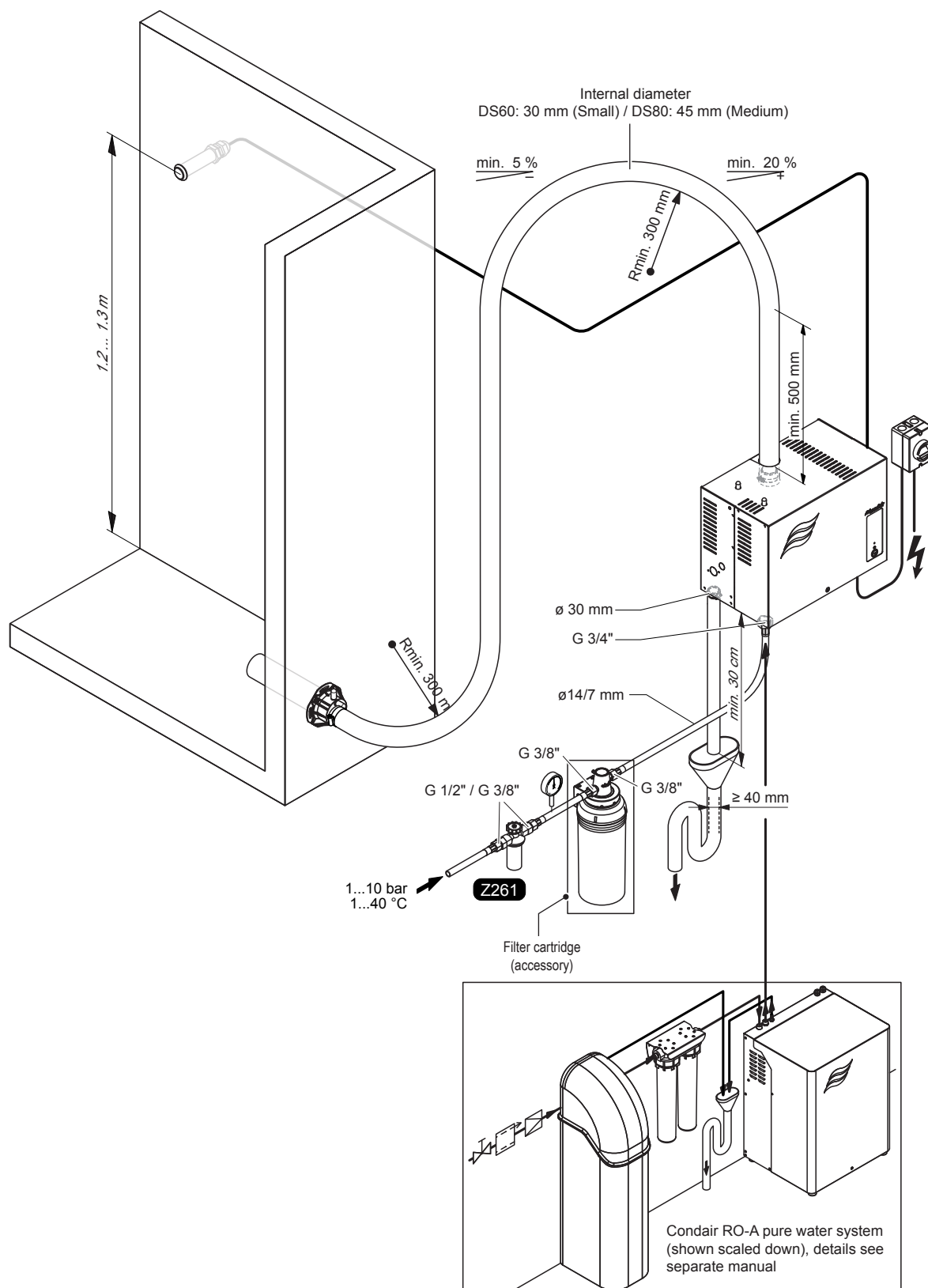

Fig. 12: Installation overview (Version with water inlet and outlet connection on the bottom of the unit)

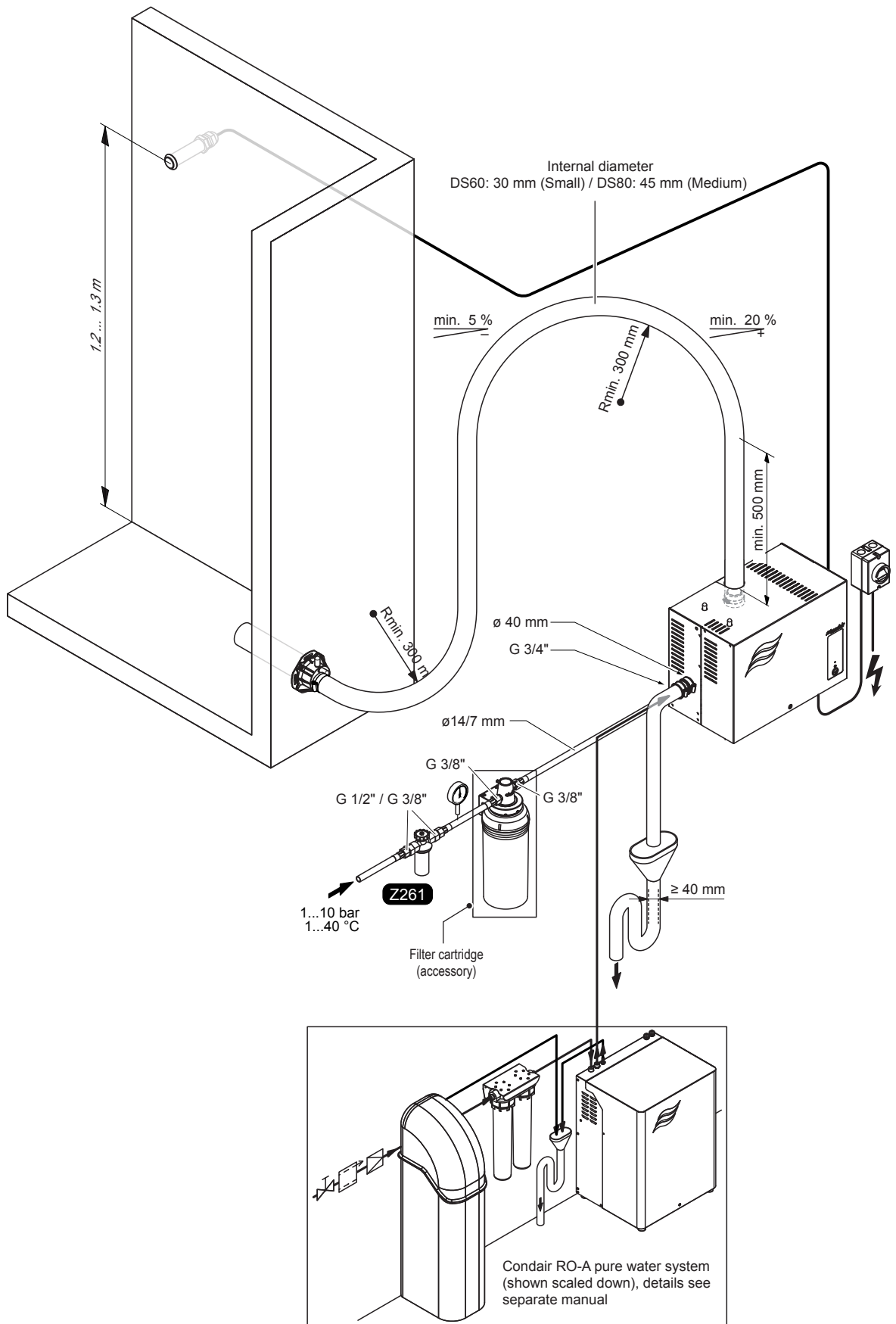

Fig. 13: Installation overview (Version with lateral water inlet and outlet connection)

6.3 Mounting the unit

6.3.1 Notes on locating the unit

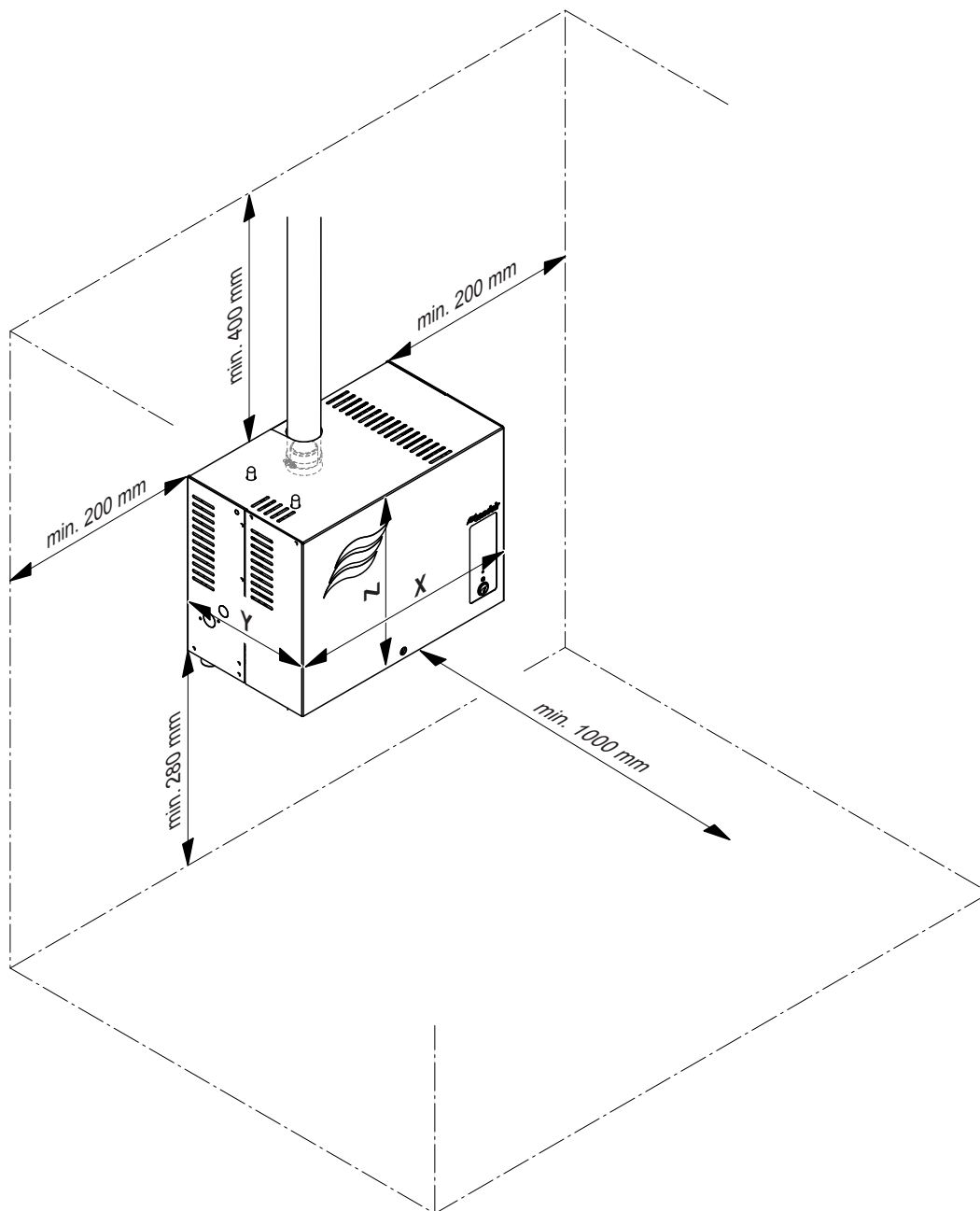

Fig. 14: Distances to be observed

Condair Omega		2...8 (Small)	12...20 (Medium)
Housing dimensions in mm	X	470	470
	Y	150	270
	Z	350	350
Net weight in kg		10.6	14.4
Operation weight in kg		12.9	19.6

The installation site of the Condair Omega depends largely on the location of the steam distributor. To **ensure proper functioning** of the steam generator and to **obtain an optimal efficiency**, the following points must be considered and observed when choosing the location for the steam generator:

- Install the steam generator so that:
 - the **length of the steam** line is kept as short as possible (**max. 8 m**),
 - the **minimum bend radius for steam hoses (R= 300 mm)** and for **solid steam pipes (5 x internal diameter)** and the minimum **upslope** and **downslope (min. 20 %)** of the steam lines is maintained (see [chapter 6.4.3](#)).
- The Condair Omega is designed for wall-mounting or floor mounting (with the optional floor supports) in protected interiors. Make sure that the construction (wall, pillar, floor-mounted console, etc.) to which or on which the steam generator is to be mounted, offers a **sufficiently high load-bearing capacity** (take notice of the weight information found in the dimensions and weights table after [Fig. 14](#)), and is suitable for the installation.
- The back panel of the Condair Omega retains heat during operation (max. surface temperature of the metal housing approx. 60 - 70 °C). Make sure, therefore, that the construction (wall, pillar, etc.) to which or on which the unit is to be mounted, does not consist of heat-sensitive material.
- Install the Condair Omega in such a manner that it is **freely accessible** with sufficient space available for maintenance purposes. The **minimum distances** shown in [Fig. 14](#) **must be maintained**.
- The Condair Omega is protected according to **IP20**. Make sure the unit is installed in a drip-proof location and the admissible ambient conditions are complied with.
- The Condair Omega **must not be installed in the SPA cabin** (steam shower, stem bath, etc.), but in a separate room with normal room conditions.
- Do **not** mount the Condair Omega to hot or very cold walls or near vibrating components.
- The steam generator Condair Omega must only be installed in rooms with a floor drain.



CAUTION!

If for some reason the Condair Omega must be installed in a location without floor drain, it is mandatory to provide a leakage monitoring device to safely interrupt the water supply in case of leakage.

- Important: The ambient pressure at the place of installation of the Condair Omega and the steam distributor must be equal.
- When mounting the Condair Omega use **only the mounting materials supplied with the unit**. If mounting with the materials supplied is not possible in your particular case, select a method of mounting that is of similar stability.
- The Condair Omega is designed for installation and operation within buildings (admissible temperature range 5...40 °C). For outdoor operation the Condair Omega must be placed in a weather protective housing. If ambient temperatures near or below the freezing point have to be expected, the protective housing must be equipped with a thermostat controlled heating of sufficient capacity. The water supply pipe must be equipped with a trace-heating and must be insulated up to the protective housing. The installation of a normally open valve inside the building envelope that will drain water in case of power failure is highly recommended.

6.3.2 Wall mounting

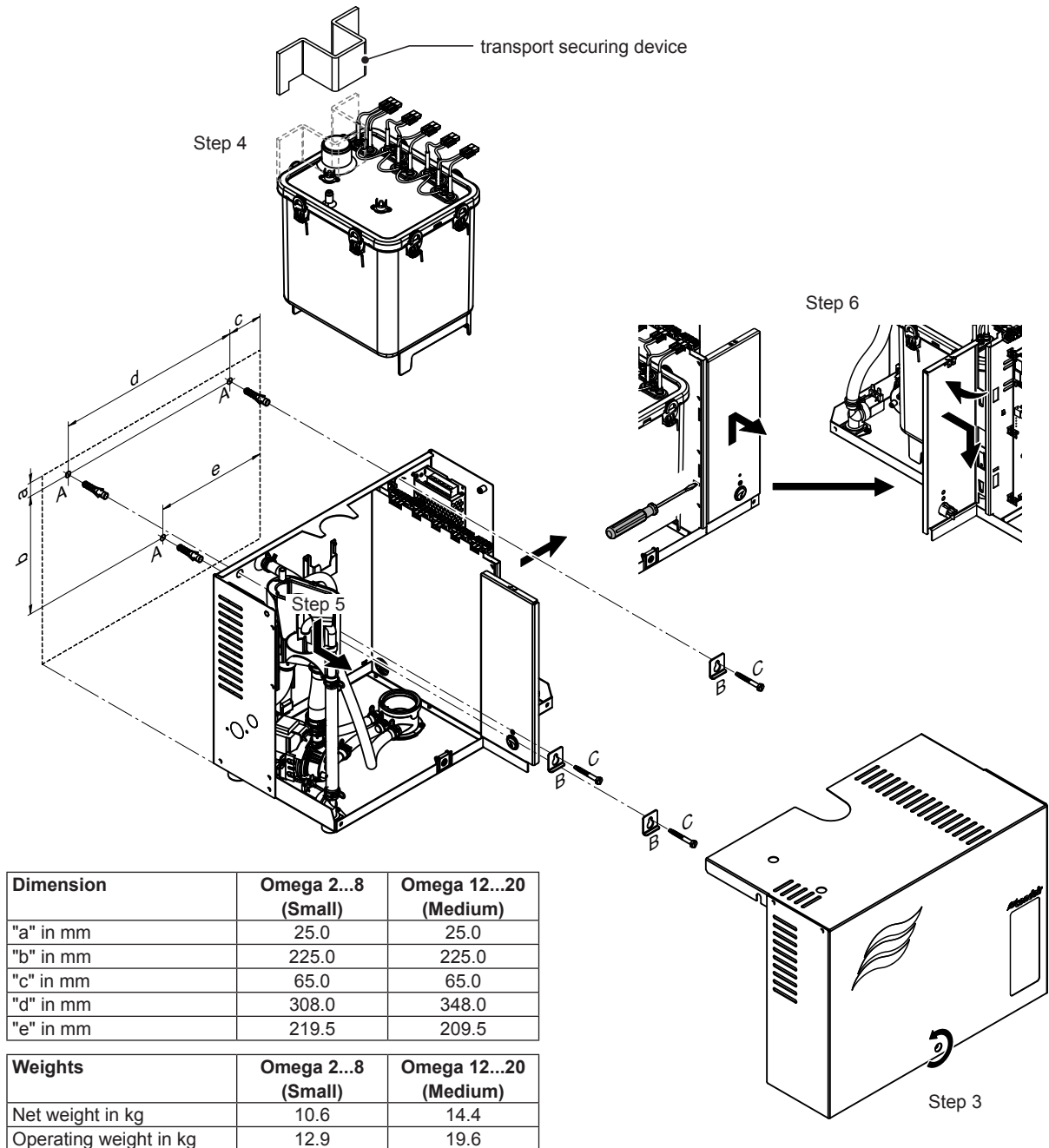

Fig. 15: Mounting the steam generator to a wall

Procedure

1. Mark the attachment points "A" at the desired position with the help of a spirit level. Then, drill holes diameter: 8 mm, depth: 40 mm.
2. Insert the supplied plastic plugs. Then, screw in the supplied screws 5 x 40 mm into the plastic plug in such a way that the distance between screw head and unit rear wall is 10 mm.
3. Unlock the retaining screw of the unit cover, then remove the unit cover.
4. Remove transport securing device located on top of the steam tank, disconnect all heating cables and the connecting cables to the overtemperature switch(es). Then, pull steam tank out of the coupling sleeve and remove.

5. Carefully pull the fixing clip of the filling cup out of the support, then push filling cup down and pull it to the front out of the support.
6. From the left side release the locking lug of the swivel plate with the unit switch using a screw driver. Then, push swivel plate upwards until it comes to a stop and remove it from the openings in the housing. Turn swivel plate 90° outwards and hang it into the corresponding openings in the housing.
7. Hang the steam generator onto the screws. Insert the supplied locking plates "B" between screw head and unit rear wall. Align the steam generator horizontally using a spirit level, then fasten the screws.
8. Moisten the O-ring in the steam tank receptacle with water (do not use grease or oil). Then, insert the stirrup on the backside of the steam tank into the retaining bracket on the back wall of the unit housing. Insert the connector on the bottom side of the steam tank into steam tank receptacle and push steam tank downwards until it comes to a stop.
Important: Check whether the steam tank is correctly hooked in the retaining bracket on the back wall of the unit housing by pulling the steam tank to the front. A correctly mounted steam tank cannot be moved.
9. Connect heating cable plugs into the corresponding sockets (see [Fig. 16](#)).
Important: make sure the cables are not crossed!
Attach connecting cables to the connectors of the overtemperature switch(es).

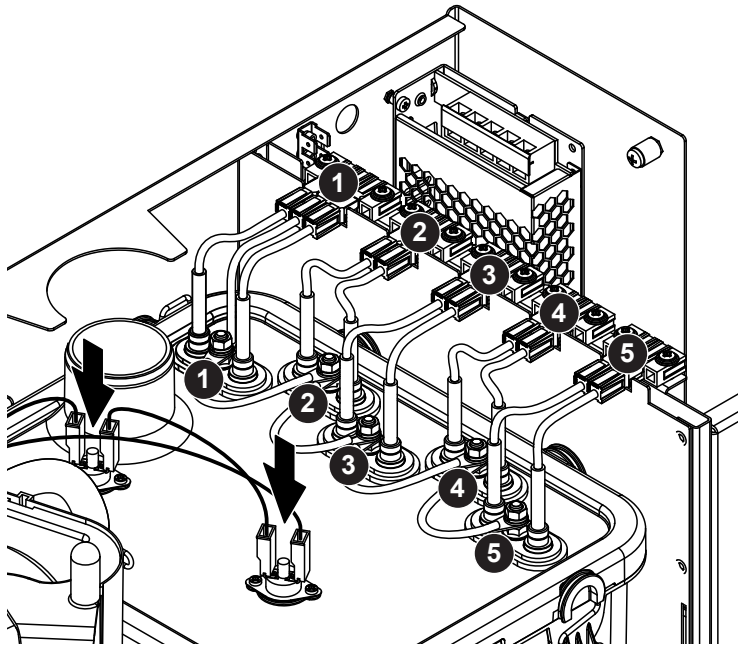
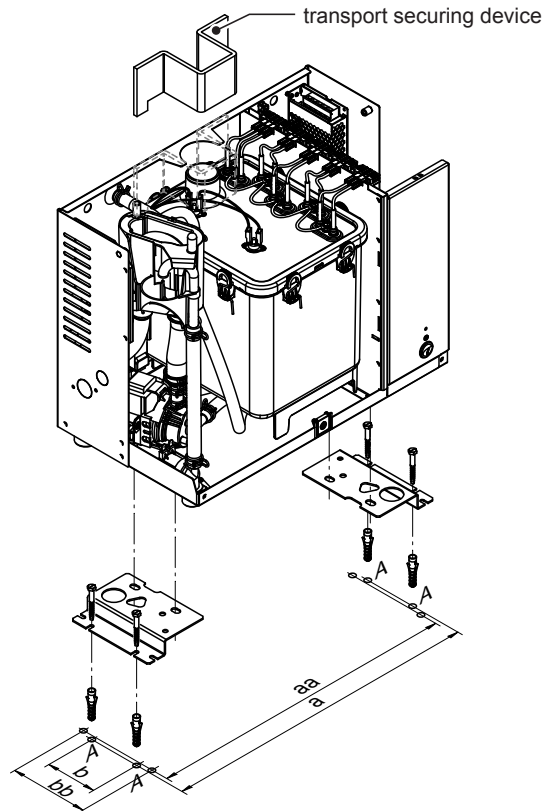

Fig. 16: Connecting the heating cables and the connecting cables of the overtemperature switch(es)

10. Insert the hocks of the filling cup into the opening in the filling cup support. Push filling cup upwards until the fixing clip engages.
Important: make sure the drain hose from water cup is inserted into the drain opening on the bottom of the unit housing.
11. Push the swivel plate with the unit switch upwards until it comes to a stop and remove it from the openings in the housing. Turn swivel plate 90° inwards and hang it into the corresponding openings in the housing, then push swivel plate downwards until the locking lug engages.
12. Reattach the unit cover and secure it with the retaining screw.

6.3.3 Floor mounting



Dimension	Omega 2...8 (Small)	Omega 12...20 (Medium)
"a" in mm	512	512
"b" in mm	84	84
"aa" in mm	499	499
"bb" in mm	128	128

Weights	Omega 2...8 (Small)	Omega 12...20 (Medium)
Net weight in kg	10.6	14.4
Operating weight in kg	12.9	19.6

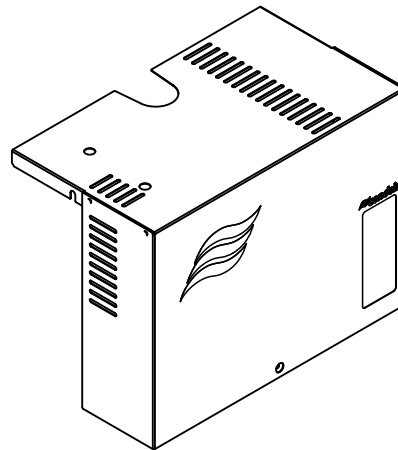

Fig. 17: Mounting the steam generator to the floor

Procedure

1. Screw the two floor supports to the steam generator from below with 2 screws on each side of the device
2. Mark the attachment points "A" (two on each side of the device) at the desired position. Then, drill holes diameter: 8 mm, depth: 40 mm.
Note: The mounting surface must be level in both directions (check with a spirit level).
3. Insert the supplied plastic plugs into the holes.
4. Fix the device to the floor using the screws supplied.
5. Unlock the retaining screw of the unit cover, then remove the unit cover. Remove transport securing device located on top of the steam tank. Reattach the unit cover and secure it with the retaining screw.

6.3.4 Inspecting the installed unit

Check the following points:

- Is the unit installed in the correct place (see [chapter 6.3.1](#))?
- Is the supporting surface stable enough?
- Is the unit correctly aligned, vertically and horizontally?
- Is the unit properly secured (see [chapter 6.3.2](#) and [chapter 6.3.3](#))?
- Has the unit cover been relocated and correctly fixed with the screw?

6.4 Steam installation

6.4.1 Overview steam installation

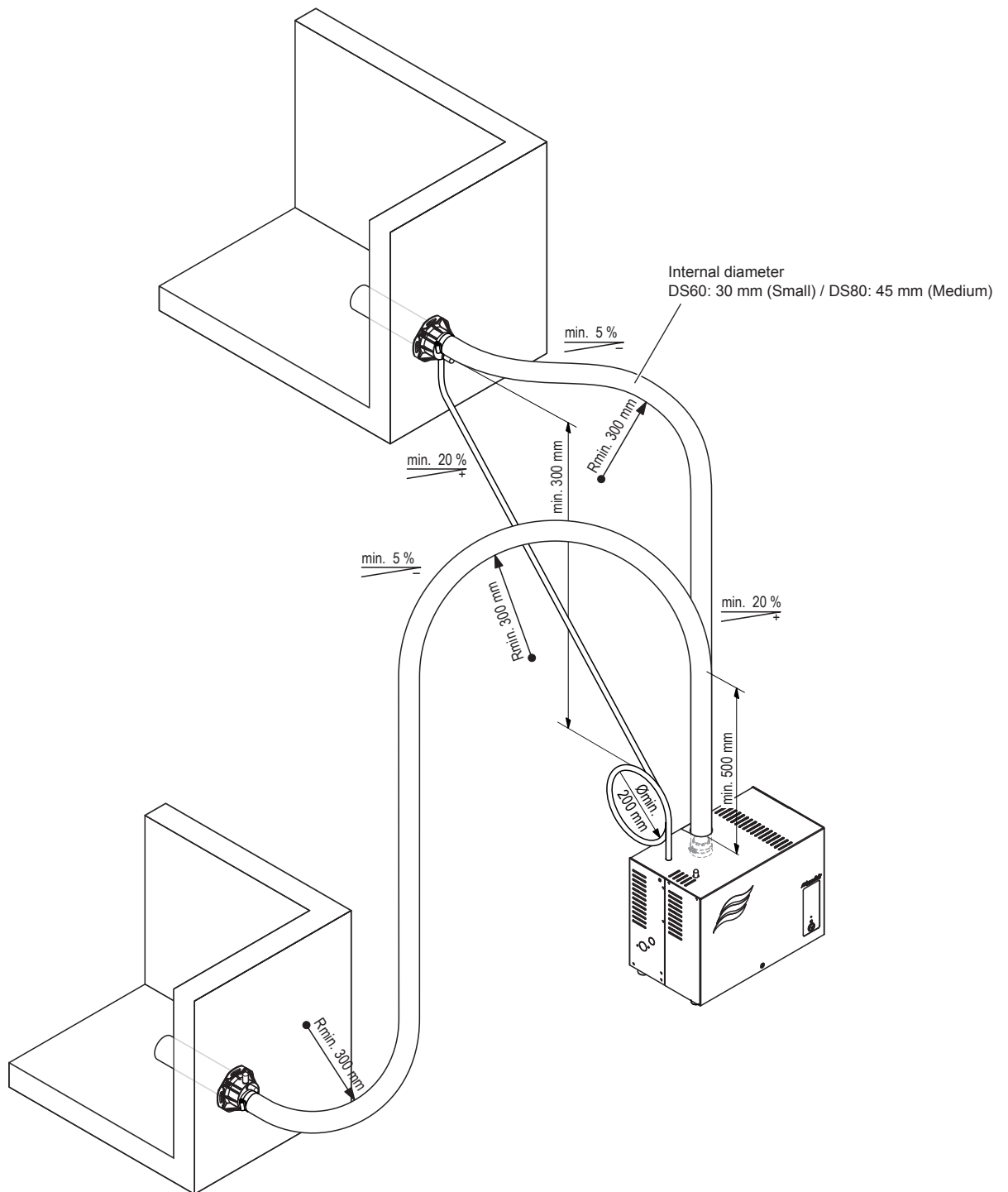

Fig. 18: Overview steam installation

6.4.2 Positioning/mounting the steam distributor

It's the responsibility of the customer to correctly position the steam distributor in the steam bath cabin.



WARNING!
Hot water vapour - Danger of scalding!

Shield the steam outlet of the steam distributor with corresponding measures to make sure steam bath users can not be burned by the steam flow.

Important: The ambient pressure at the place of installation of the Condair Omega and the steam distributor must be equal.

6.4.3 Installing the steam and condensate lines

6.4.3.1 Notes on installing the steam and condensate lines

- Use **original steam and condensate hose** from your Condair representative or **solid steam pipes from copper or stainless steel (min. DIN 1.4301) exclusively**. Steam and condensate lines from other material may cause undesired operational malfunctions.
- Initially, lead the steam line **upright upwards min. 300 mm above the steam generator**. Then lead the steam line with a **minimum upslope of 20 %** and/or a **minimum downslope of 5 %** to the steam distributor.
Important: ensure the steam hose can be disconnected later on from steam outlet connector on steam tank for maintenance purpose. For that purpose the steam hose may be led more than 500 mm upright upwards.
- The condensate hose from the steam distributor is led down to the steam generator with a **minimum downslope of 20 %**, via a condensate trap (**min. hose bend diameter Ø200 mm**) and there it is to be connected to the appropriate connector on top of the unit (left connector= condensate flows back into the steam tank (not recommended), right connector= condensate flows into the drain). Alternatively the condensate hose can be led also directly into an open funnel.
Important! Before putting the unit into operation, the condensate trap of the condensate hose must be filled with water.
- The steam line should be kept as short as possible (**max. 8 m** while observing the **minimum bend radius of 300 mm** (for steam hoses) or **5 x internal diameter** (with solid steam pipes), respectively).
Important! Allowance must be made for a **pressure loss of approx. 100 Pa** per meter steam line and per 90° elbow.
- **Important!** When deciding on the length and layout of steam hoses, it should be noted that steam hoses may become shorter and/or longer depending on temperature and age.
- The steam hose must be secured to the steam distributor and steam generator steam outlet by means of **hose clamps**. Solid steam pipes should be connected to the steam distributor and steam generator with short lengths of steam hose secured with hose clamps.
Caution! Do not overtighten the hose clamp on the steam connector of the steam generator.



WARNING!

Make sure that there is no tension on the steam hose since this could result in lifting the steam tank out of the coupling sleeve. If necessary fix steam hose right before the steam generator with a strain relief device.

- Steam lines made of solid pipes (copper or stainless steel) must be insulated over the entire length to minimize condensate formation (=loss).



DANGER!

Reducing the cross section or the complete closure of the steam line will cause an excessive increase in pressure in the steam tank when the unit is operating and could lead to the risk of scalding accidents. All installations must comply with the following instructions.

- When installing make sure the steam line is open over the entire length and through the whole cross section. Any sealing plugs, adhesive sealing sheets etc. must be removed before connecting the steam pipe. Reductions in cross section by kinking or crushing must be avoided.
- Steam hoses must be prevented from sagging (condensate pockets); if necessary, support steam hose with pipe clamps, trough, or wall brackets, and install a condensate drain at any low points in the steam line.
- It is **not permitted to install a stop valve** (e.g. a manually controlled stop valve, solenoid valve, etc.) in the steam line, due to an inadmissible increase of pressure in the steam tank if the valve is closed during the operation.

6.4.3.2 Installation examples

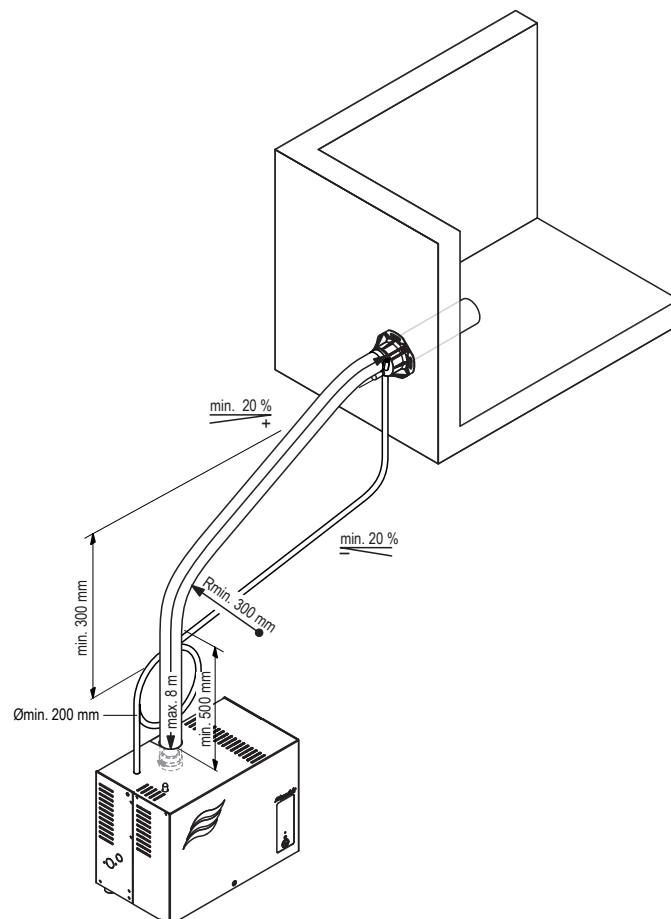

Fig. 19: Steam distributor is mounted more than 500 mm above the top edge of the steam generator

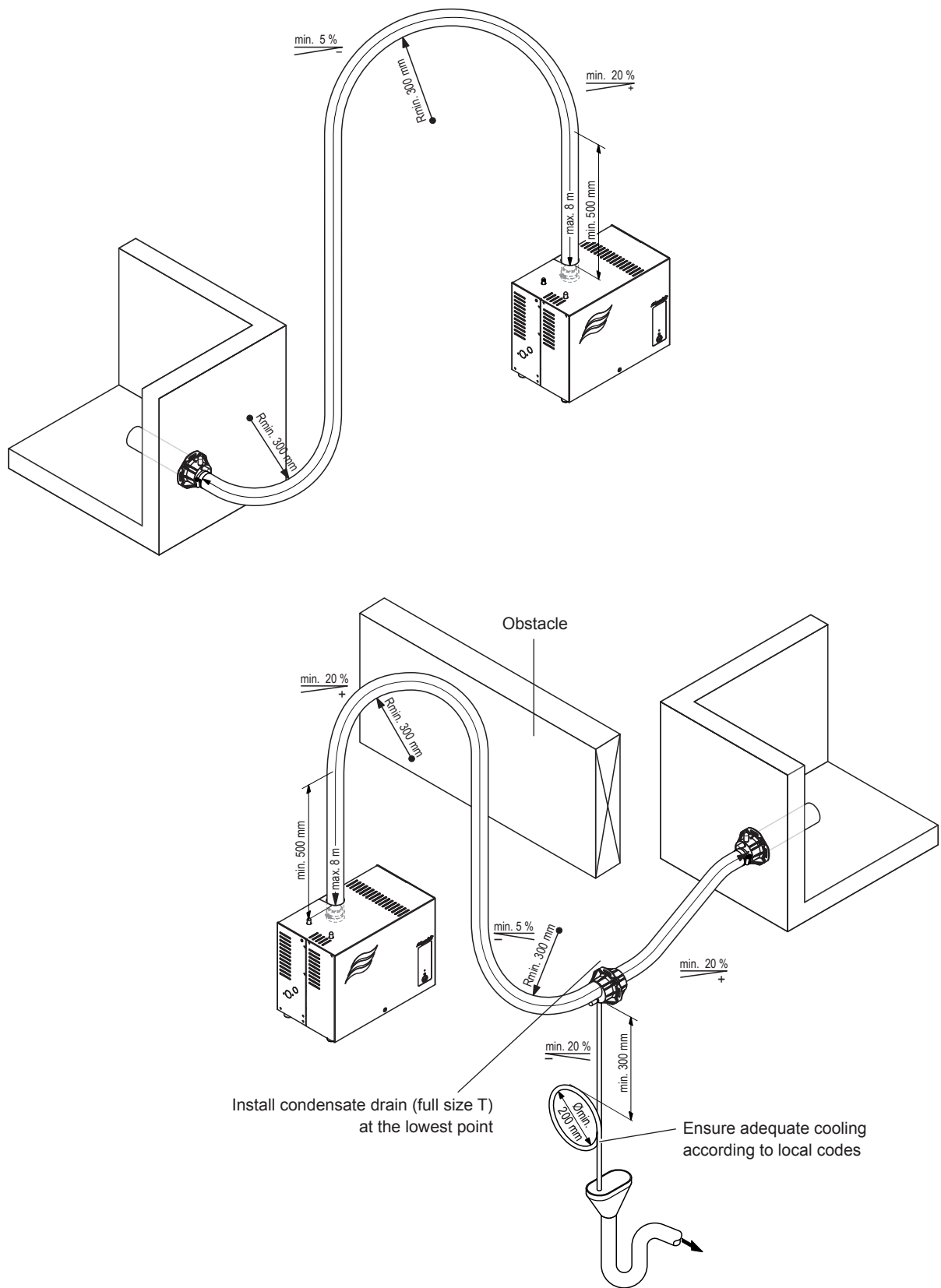

Fig. 20: Steam distributor is mounted less than 500 mm above the top edge of the steam generator

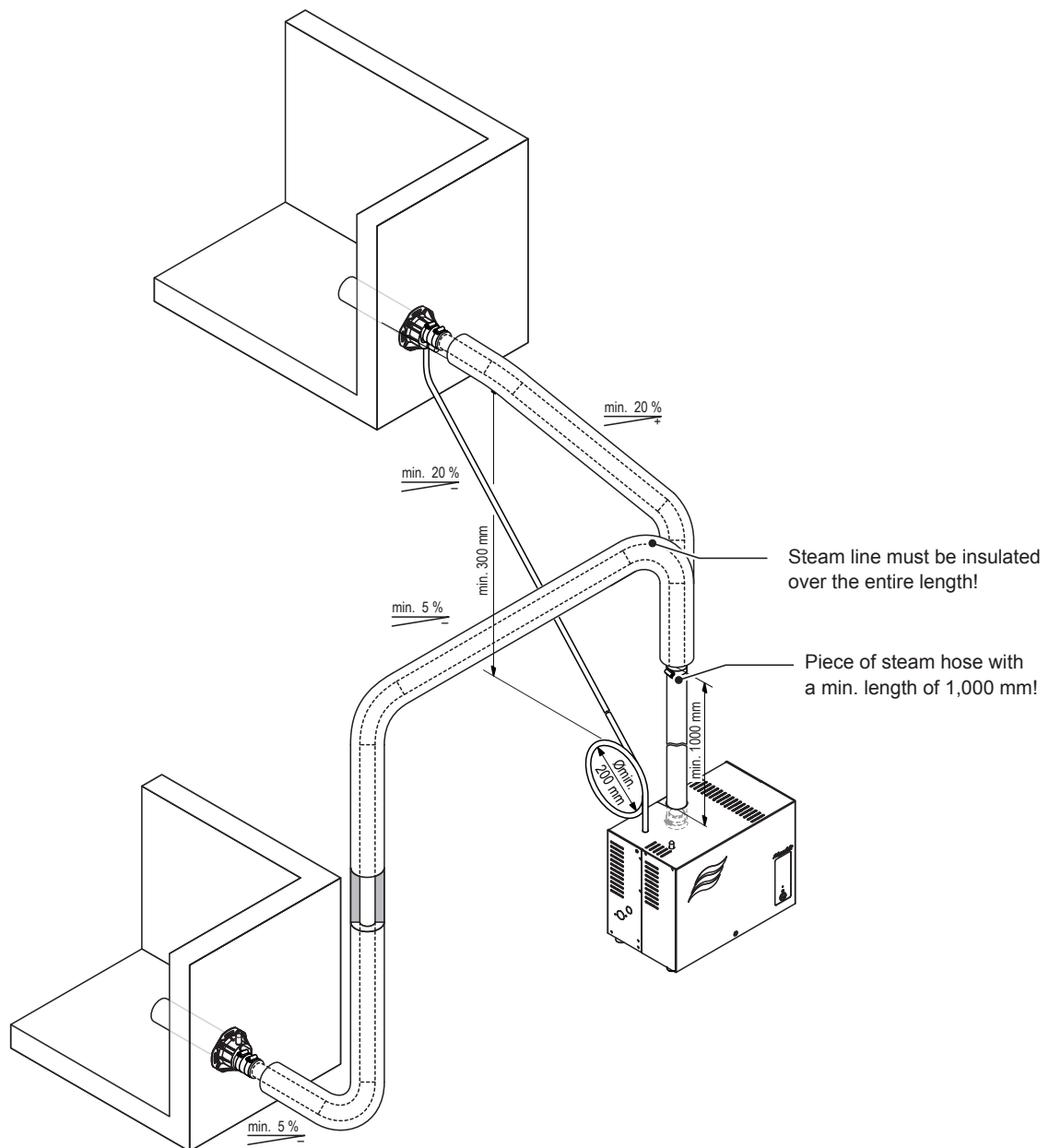
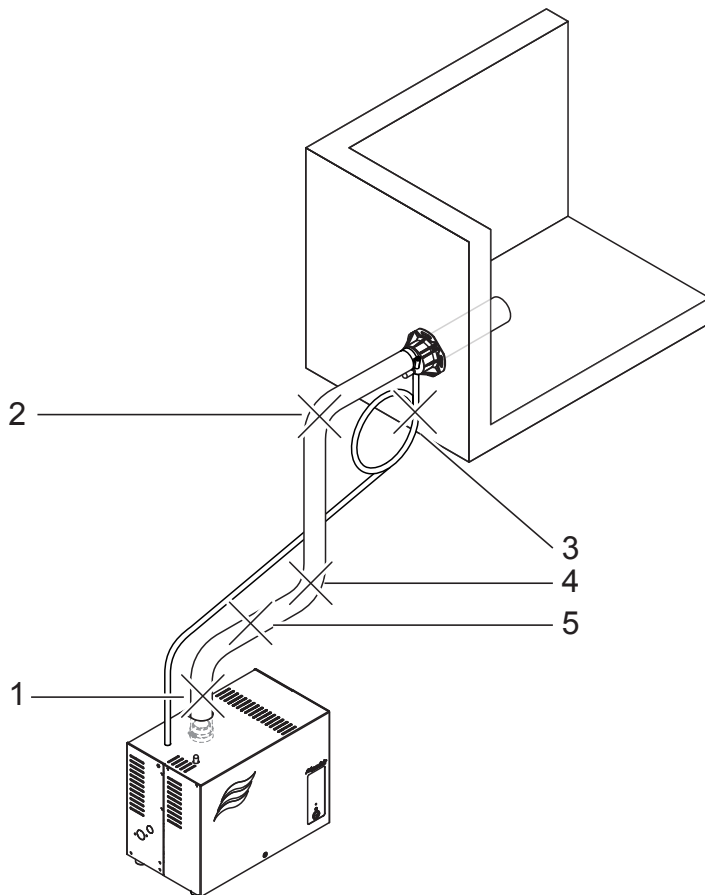

Fig. 21: Steam line with solid piping and insulation

The following notes should be observed:

- The **minimum internal diameter of the steam line** (diameter dependent on the steam generator) should be applied over the entire length of the piping.
- Use exclusively stainless steel (recommended, min. DIN 1.4301) or copper pipe.
- To minimize the condensate formation (=loss), the steam pipes must be insulated.
- Connection of the steam pipes to the steam distributor and the steam outlet connector on the steam tank is effected with pieces of steam hose with an appropriate length (the length of the steam hose connected to the steam outlet of the steam generator must be min. 1,000 mm) secured with hose clamps.
- **Important!** Allowance must be made for a **pressure loss of approx. 100 Pa** per meter length or per 90° bend.

6.4.4 Common steam and condensate line errors



	Wrong	Correct
1	Steam hose/steam hose piece not led at least 500 mm (for steam hoses) or 1,000 mm (for solid piping) perpendicularly upwards before first bend (forming of condensate).	Lead steam hose/steam hose piece at least 500 mm (for steam hose installations) or 1,000 mm (for solid pipe installation) perpendicularly upwards before first bend.
2	Minimum bend radius of steam hose/solid steam line not maintained (forming of condensate).	The minimum bend radius of 300 mm for steam hoses or 5 times steam line internal diameter for solid steam lines must be maintained.
3	Condensate trap not sufficiently high and installed too near at the steam distributor.	The condensate trap must be at least 300 mm below the connector on the steam distributor and it must have a minimum height of 200 mm (ø200 mm).
4	No condensate trap installed at vertical transition.	Install condensate trap at all low points and before vertical transitions.
5	Steam line and condensate hose not sloped (slope min. 20 %).	Install steam line always with constant up or downslope of min. 15 % (8.5°) and condensate hose with constant downslope of min. 15 % (8.5°).

Fig. 22: Common steam and condensate line errors

6.4.5 Inspecting the steam installation

Use the following check list to ascertain that the steam installation was performed correctly:

- Steam distributor
 - Steam distributors correctly positioned and secured (screws tightened)?
 - Are unused condensate connectors on the steam distributor closed with a cap?
- Steam hose
 - Is maximum steam line length of 8 m maintained?
 - Is minimum steam hose length of 500 mm (for steam hose installations) or 1,000 mm (for solid pipe installation) maintained before first bend and led perpendicularly upwards?
 - Is upslope of at least 20 % or downslope of at least 5 % maintained?
 - Is minimum bend radius of 300 mm for steam hose maintained?
 - Have the instructions for hose positioning been followed?
 - Steam hose: no sagging (condensate pocket) or condensate drain with siphon (hose bend with a minimum diameter of 200 mm) installed at the lowest point?
 - Steam hose(s) securely attached with clamps?
 - Heat expansion during operation and shortening of the hose with ageing taken into consideration?
 - Rigid steam lines: properly insulated? Correct installation material used? Minimum internal diameter maintained?
- Condensate hose
 - Downslope of at least 20 %?
 - Siphon (min. \varnothing 200 mm) existing and filled with water?
 - Condensate hose correctly fixed and not kinked?

6.5 Water installation

6.5.1 Overview water installation

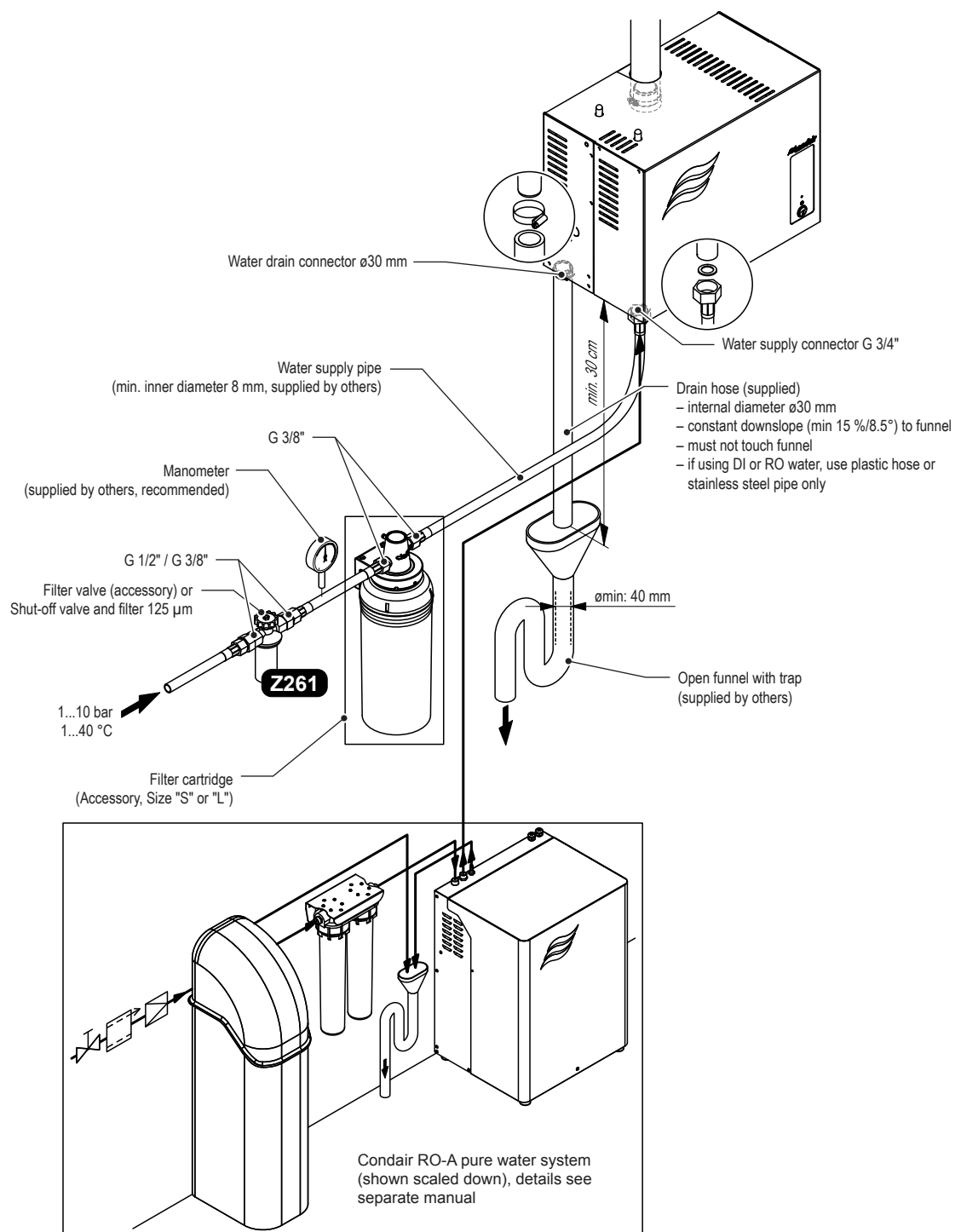

Fig. 23: Overview water installation (connections on the bottom of the unit)

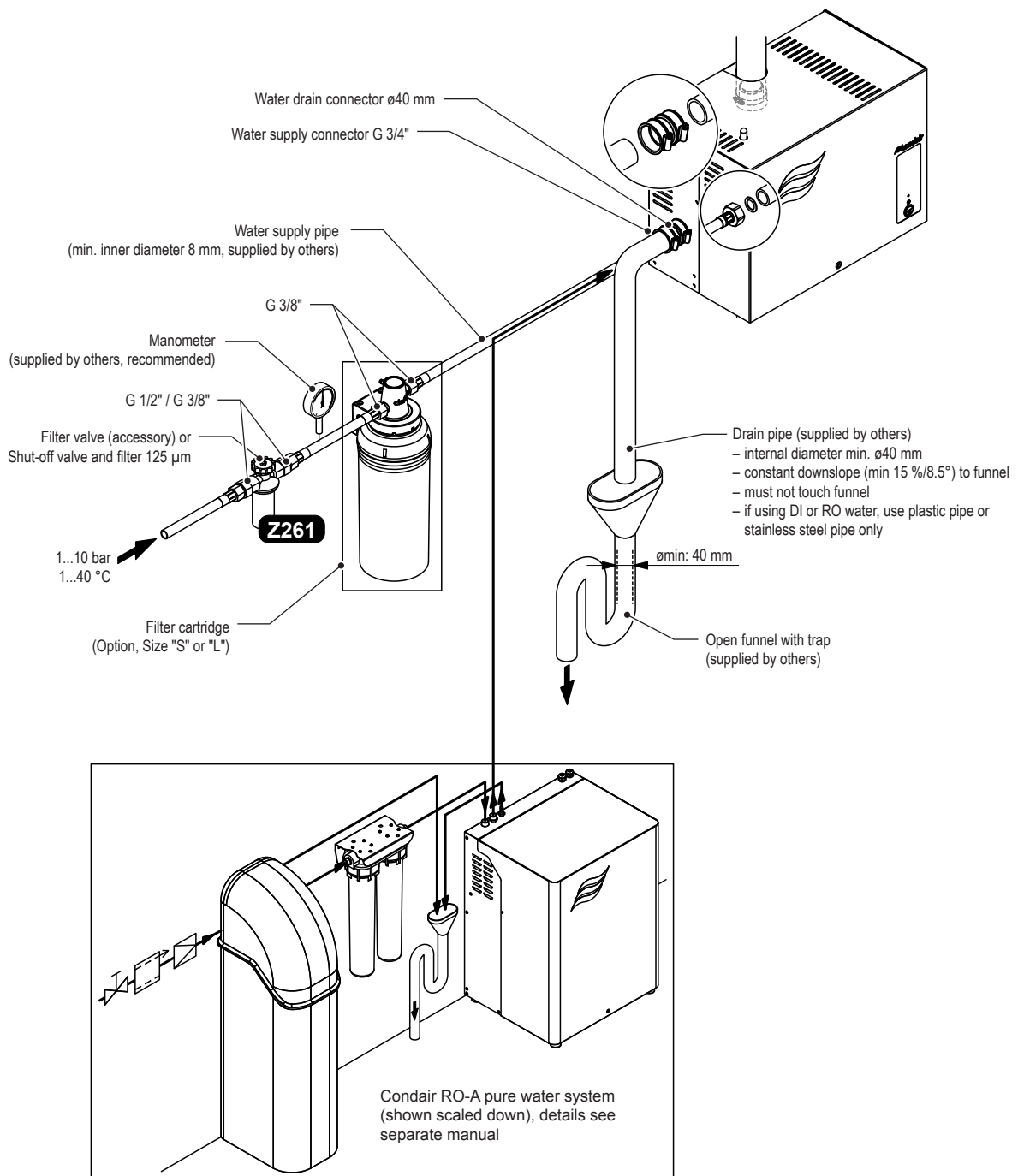

Fig. 24: Overview water installation (connections on the left side of the unit)

6.5.2 Notes on water installation

Notes: For the mounting of the optional filter cartridge please refer to notes given in the separate manual supplied with filter cartridge.

Water supply

The water supply is to be carried out according to the corresponding figure (see [Fig. 23](#) or [Fig. 24](#)) and the applicable local regulations for water installations. The indicated connection specifications must be observed.

- The installation of the **filter valve** (accessory "Z261", alternatively a shut-off valve and a water filter can be used) should be made as close as possible to the steam generator.
- Admissible mains pressure **1.0 to 10.0 bar (hammer-free system)**
For mains pressures >10 bar, the connection must be made via a pressure reducing valve (adjusted to 1.0 bar). For mains pressures <1.0 bar please contact your Condair supplier.
- **Notes on water quality:**
 - For the water supply of the Condair Omega, use exclusively untreated drinking water, water from RO system (e.g. Condair RO-A) or demineralised water from the filter cartridge (accessory).
 - The use of **additives** in the water such as fragrance liquids, corrosion inhibitors, disinfectants, etc. is **not allowed**, since these additives may endanger health and affect proper operation.
 - If the Condair omega shall be operated with softened or partly softened water, please contact your Condair representative.
- The connection material must be **pressure-proof** and **certified for use in drinking water systems**.
- **Important!** Before connecting the water line, **the line should be well flushed out and deaerated**.



CAUTION!

The thread at the steam generator connection is made of plastic. To avoid overtightening, the union nut of the water pipe must be **tightened by hand** only.

Water drain

The water drain is to be carried out according to the corresponding figure (see [Fig. 23](#) or [Fig. 24](#)) and the applicable local regulations for water installations. The indicated connection specifications must be observed.

- Make sure that the drain pipe, the funnel and the siphon are correctly fixed and easily accessible for inspections and cleaning purposes.
- The draining temperature is: **80...90 °C**. Use temperature-resistant installation materials only!
- Attach drain line in such a way, that it cannot slip out of the funnel.
- The open end of the drain line must not touch the funnel (min. air gap 2 cm).

6.5.3 Inspecting the water installation

Check the following topics:

- Water supply
 - Has filter valve (accessory "Z261") or shut-off valve and 5 µm water filter respectively been installed in supply line?
 - Have admissible water pressure (1 – 10 bar) and admissible temperature (1 – 40 °C) been observed?
 - Does the supply capacity match the steam generator and is the minimum internal diameter of 8 mm of the supply pipe maintained throughout the entire length?
 - Are all components and pipes properly secured and are all threaded connections securely tightened?
 - Is the water system properly sealed?
 - Does the water supply installation meet the requirements of the local regulations for water installations?
- Water drain
 - Is the minimum internal diameter of the drain pipe from the unit to the funnel of ø30 mm maintained throughout the entire length?
 - Is the minimum internal diameter of the drain pipe from the funnel to the waste water line of the building of ø40 mm maintained throughout the entire length?
 - Has drain pipe been installed with a downslope of at least 15 %?
 - Has the heat resistance of the material used been verified to be at least 100 °C?
 - Is the drain hose properly secured (hose clamps at unit connection tightened)?
 - Is there an air gap (min 2 cm) between the open end of the drain line and the funnel?
 - Does the water drain installation meet the requirements of the local regulations for water installations?

6.6 Electric installation

6.6.1 Notes on electrical installation



DANGER!
Danger of electric shock

The Condair Omega is mains powered. Live parts may be exposed when the unit is open. Touching live parts may cause severe injury or danger to life.

Prevention: The Condair Omega unit must be connected to the mains only after all mounting and installation work has been completed, all installations have been checked for correct workmanship and the unit is closed and properly locked.



CAUTION!

The electronic components inside the unit are very sensitive to electrostatic discharge. Before carrying out installations work inside the unit, appropriate measures must be taken to protect the electronic components against damage caused by electrostatic discharge (ESD protection).



WARNING!

For public saunas without heating time limit, a warning light in the room of the supervisor must be installed, which indicates when the sauna heater is on.

- All work concerning the electrical installation must be performed only by **skilled and qualified technical personnel (e.g. electrician with appropriate training) authorised by the owner**. It is the owner's responsibility to verify proper qualification of the personnel.
- The electrical installation must be carried out according to the wiring diagrams (see [chapter 6.6.3](#)), the notes on electrical installation (see [chapter 6.6.4](#)) as well as the applicable local regulations. All information given in the wiring diagram and additional notes must be followed and observed.
- All cables must be lead into the unit, via appropriate cable strain relief or grommets (supplied by others).
- Make sure the cables are adequately clamped, do not rub on any components or become a tripping hazard.
- Observe and maintain maximum cable length and required cross section per wire according to local regulations.
- Only use heat-resistant cables designed for a temperature of at least 150 °C to connect the accessory components in the cabin.
- The mains supply voltage(s) must match the respective voltage(s) stated in the corresponding wiring diagram (see [chapter 6.6.3](#)).
- Make sure that the maximum permissible loads are not exceeded ([chapter 6.6.6](#)).
- For the installation of accessory components, please observe the information in the corresponding documentation supplied by the respective manufacturer.

6.6.2 Opening/Closing the Condair Omega and the Condair Delta SPA Control Box

To open the Condair Omega and the Condair Delta SPA Control Box for the electrical installations proceed as follows:

1. Make sure the Condair Omega and/or the Condair Delta SPA Control Box are disconnected from the mains.
2. Undo the retaining screw(s) of the Condair Omega and/or the Condair Delta SPA Control Box unit cover, then remove the unit cover.
3. **For Condair Omega only:** From the left side release the locking lug of the swivel plate with the unit switch using a screw driver. Then, push swivel plate upwards until it comes to a stop and remove it from the openings in the housing. Turn swivel plate 90° outwards and hang it into the corresponding openings in the housing.

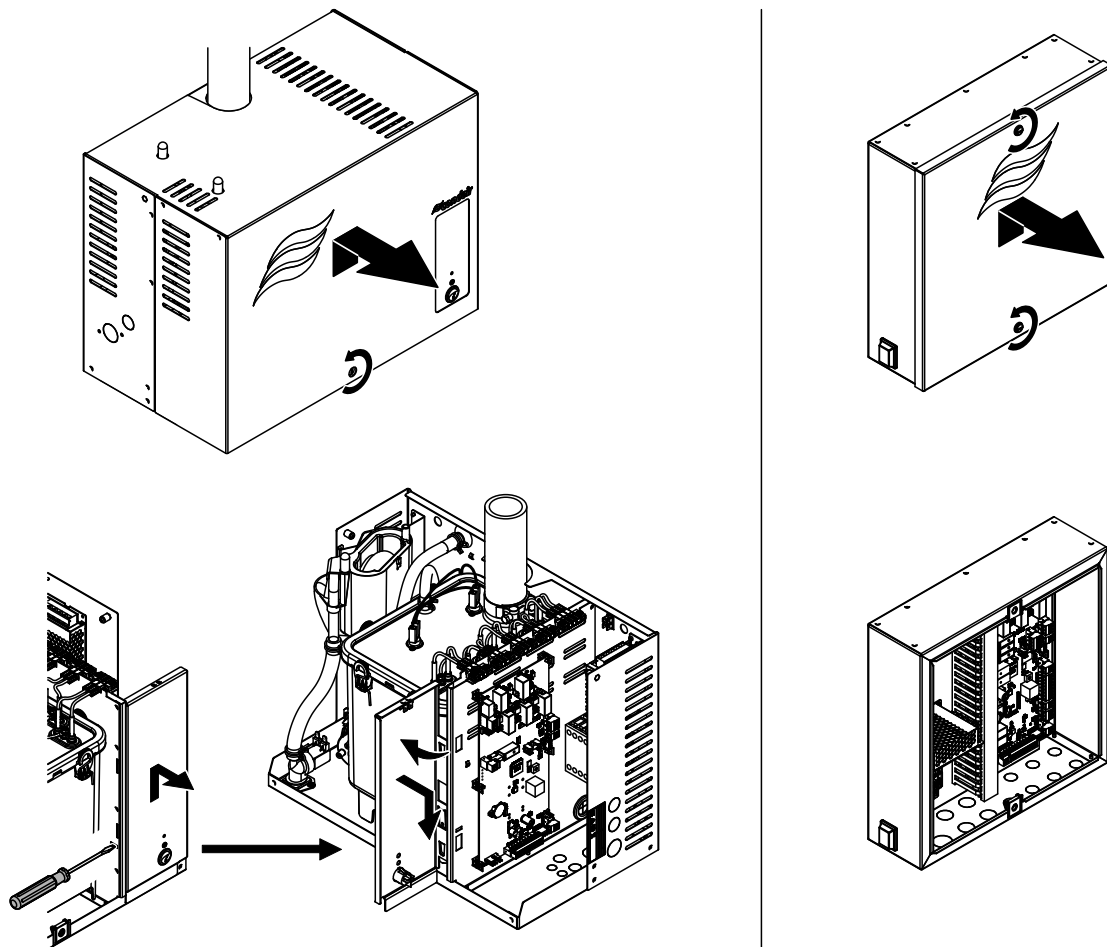
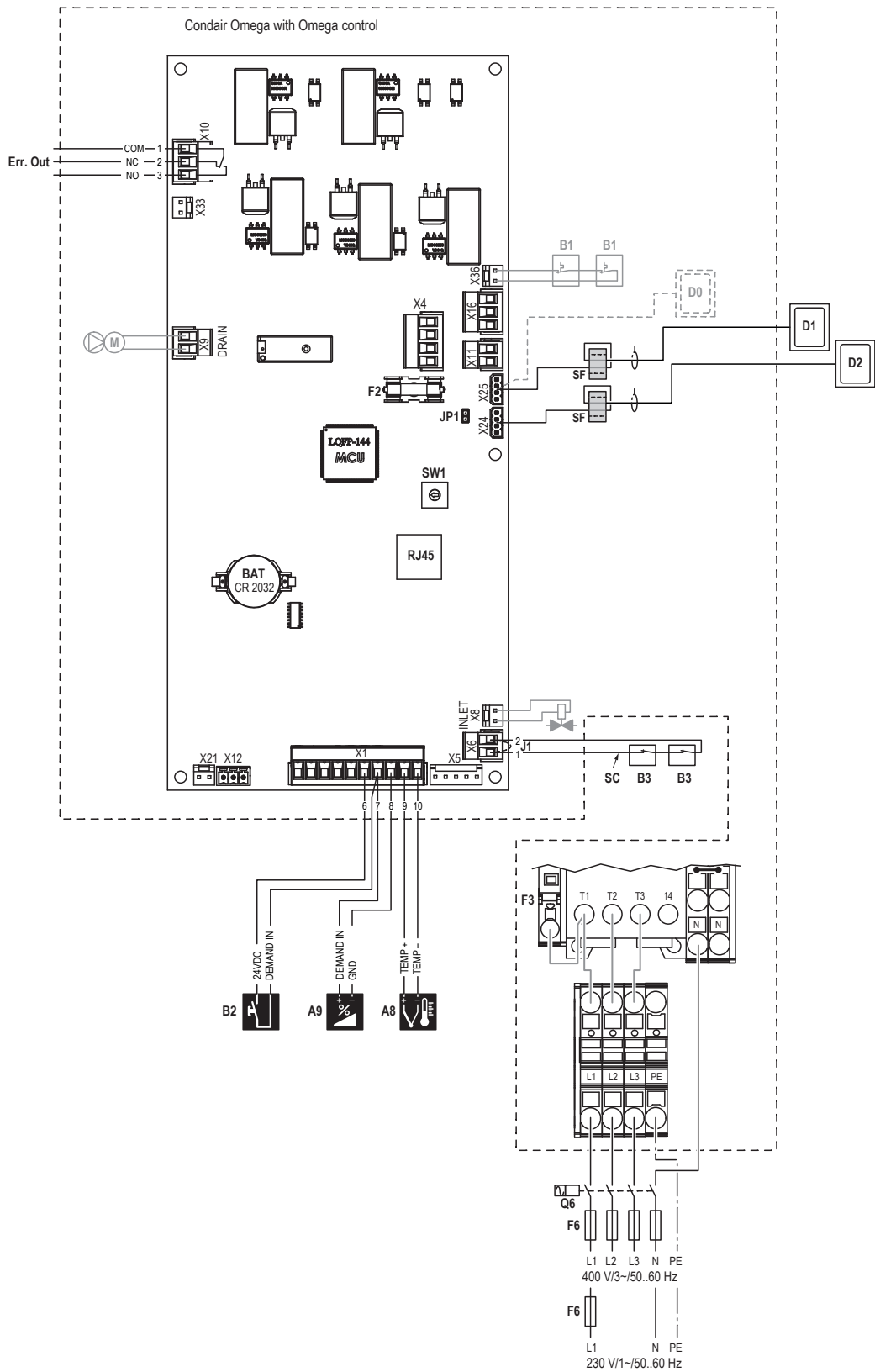

Fig. 25: Fig. 25: Opening the the Condair Omega and the Condair Delta SPA Control Box

Note: After the electrical installations inside the Condair Omega and/or inside the Condair Delta SPA Control Box are finished the Condair Omega and the Condair Delta SPA Control Box must be closed in reverse order of step 2 to 3.

6.6.3 Wiring diagrams

6.6.3.1 Wiring diagram Condair Omega with Omega control for steam shower application





Legend wiring diagram Condair Omega with Omega control for steam shower application

Symbol	Description	Remarks	Technical Details
A8	Temperature sensor	Detecting of the cabin temperature for the control of the Condair Omega via the internal controller	KTY, PT100, PT1000
A9	External temperature controller	For the control of the Condair Omega via an external temperature controller	
B1	Overtemperature switch steam tank	one or two overtemperature switches depending on the unit size	
B2	On/Off button	Starting steam operation	
B3	Safety devices (e.g. emergency stop)	Potential-free contacts	
BAT	Backup battery Omega control board		CR2032, Lithium 3V
D0	Internal SPA display (option)	See notes in chapter 6.6.4.22	
D1/D2	External SPA display(s)		
Err.Out	Fault output		
F2	Microfuse 24 VDC external		1 A, slow acting
F3	Internal fuse terminal power supply		1.6 A, slow acting
F6	External fuses power supply 230 V/1~/50...60 Hz	Condair Omega 2 kg/h	10 A, fast acting
		Condair Omega 4 kg/h	16 A, fast acting
		Condair Omega 6 kg/h	25 A, fast acting
		Condair Omega 8 kg/h	32 A, fast acting
	External fuses power supply 400 V/3~/50...60 Hz	Condair Omega 6 kg/h to 12 kg/h	16 A, fast acting
		Condair Omega 16 kg/h to 20 kg/h	32 A, fast acting
JP1	Terminating resistor CAN BUS	Remove jumper, if both CAN BUS connectors are used.	
J1	Cable bridge	Connect cable bridge to terminal block "X6", if no safety devices are connected to terminal block "X6".	
RJ45	Network connector	Network connector for the upload of software updates	
SC	Safety loop		
SF	Ferrite CAN BUS		
SW1	Rotary switch unit address	Always set to Pos. "0"	
Q6	External electrical isolator (all-pole disconnection) power supply		

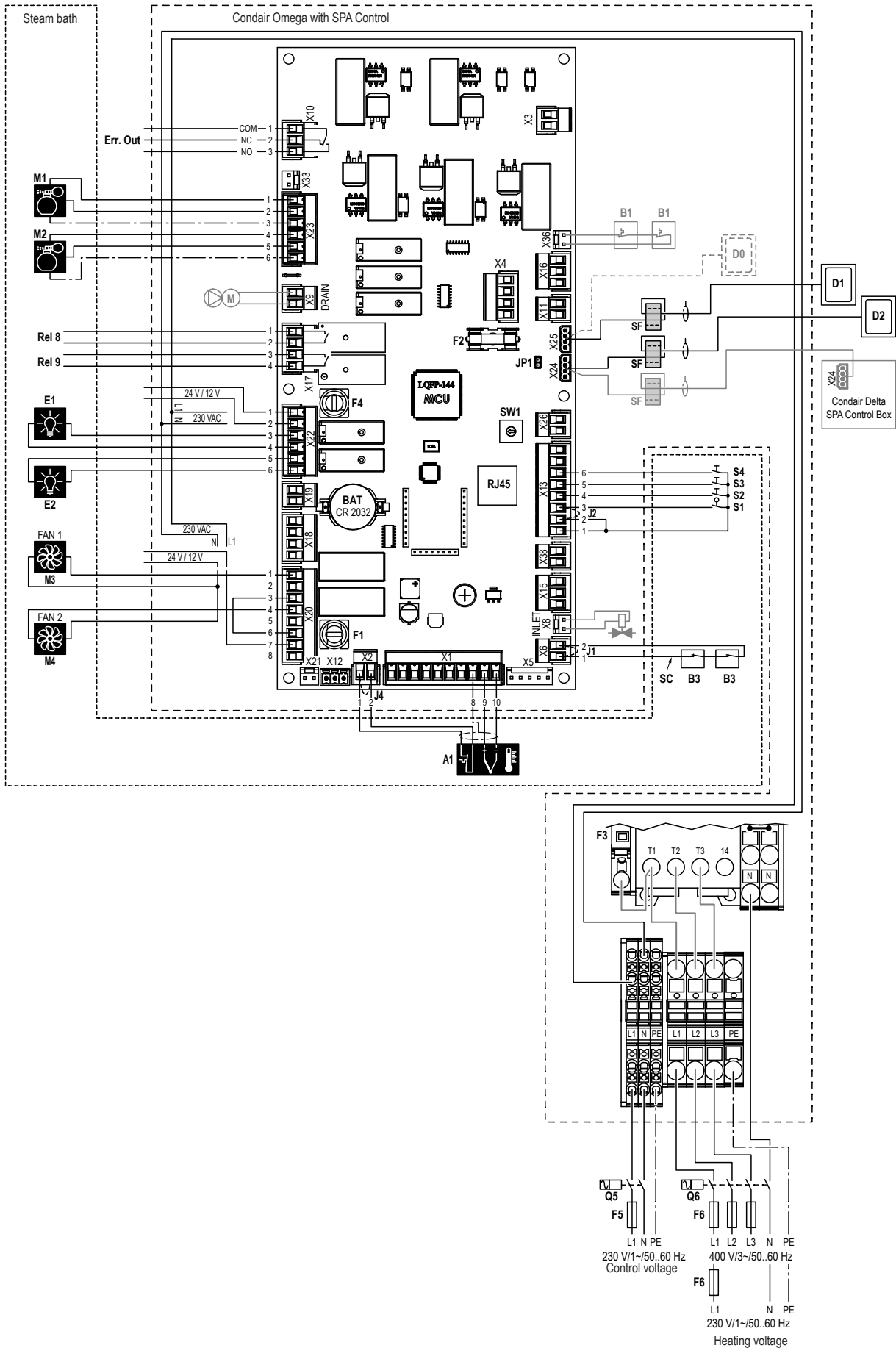
6.6.3.2 Wiring diagram Condair Omega with SPA control for steam bath application





Legend wiring diagram Condair Omega with SPA control for steam bath application

Symbol	Description	Remarks	Technical Details
A1	Temperature sensor with integrated overtemperature switch	Detecting of the cabin temperature	KTY, PT100, PT1000
B1	Overtemperature switch steam tank	one or two overtemperature switches depending on the unit size	
B3	Safety devices (e.g. emergency stop)		
BAT	Backup battery SPA control board		CR2032, Lithium 3V
D0	Internal SPA display (option)	See notes in chapter 6.6.4.22	
D1/D2	External SPA display(s)		
Err.Out	Fault output		
F1	Microfuse fans		4 A, slow acting
F2	Microfuse 24 VDC external		1 A, slow acting
F3	Internal fuse terminal power supply		1.6 A, slow acting
F4	Microfuse light		1 A, slow acting
F5	External fuse control voltage supply		16 A, fast acting
F6	External fuses heating voltage supply 230 V/1~/50...60 Hz	Condair Omega 2 kg/h	10 A, fast acting
		Condair Omega 4 kg/h	16 A, fast acting
		Condair Omega 6 kg/h	25 A, fast acting
		Condair Omega 8 kg/h	32 A, fast acting
	External fuses heating voltage supply 400 V/3~/50...60 Hz	Condair Omega 6 kg/h to 12 kg/h	16 A, fast acting
	Condair Omega 16 kg/h to 20 kg/h	32 A, fast acting	
E1	Light 1	Configurable as cleaning or color light	Maximum load: 250 V, 0.5A
E2	Light 2	Configurable as cleaning or color light	Maximum load: 250 V, 0.5A
J1	Cable bridge	Connect cable bridge to terminal block "X6", if no safety devices are connected to terminal block "X6".	
J2	Cable bridge	Connect cable bridge to terminals 2 and 3 of terminal block "X13", if no door switch is connected.	
J4	Cable bridge	Connect cable bridge to terminal block "X2", if no overtemperature switch is connected.	
JP1	Terminating resistor CAN BUS	Remove jumper, if both CAN BUS connectors are used.	
M1	Fragrance pump 1	 DANGER: 230 V output!	Maximum load: 250 V, 0.25A
M2	Fragrance pump 2	 DANGER: 230 V output!	Maximum load: 250 V, 0.25A
M3	Fan 1 (single-stage)	Control of supply and exhaust fan (configurable)	Maximum load: 250 V, 2 A
M4	Fan 2 (single-stage)	Control of supply and exhaust fan (configurable)	Maximum load: 250 V, 2 A
Rel 8	Potential-free relay contact	Function freely configurable	Maximum load: 250 V, 10A
Rel 9	Potential-free relay contact	Function freely configurable	Maximum load: 250 V, 10A
RJ45	Network connector	Network connector for the upload of software updates	
SC	Safety loop		
SF	Ferrite CAN BUS		
SW1	Rotary switch unit address	See notes in chapter 6.6.4.22	
S1	Door switch		
S2	Start-/Stop button		
S3	Light 1 button		
S4	Light 2 / Steam blast button		
Q5	External electrical isolator (all-pole disconnection) power supply		
Q6	External electrical isolator (all-pole disconnection) power supply		

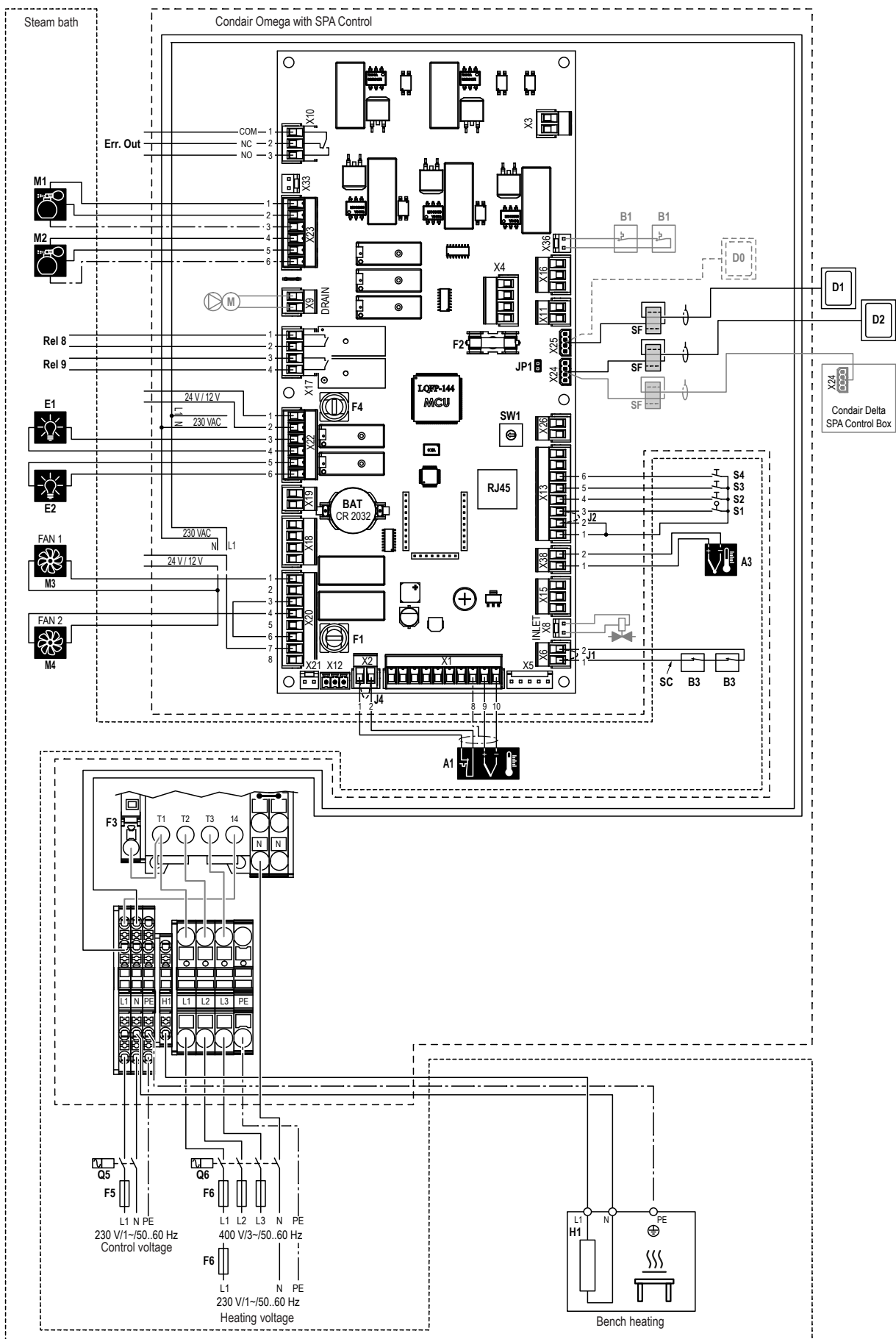
6.6.3.3 Wiring diagram Condair Omega with SPA control for steam bath application with optional bench heating





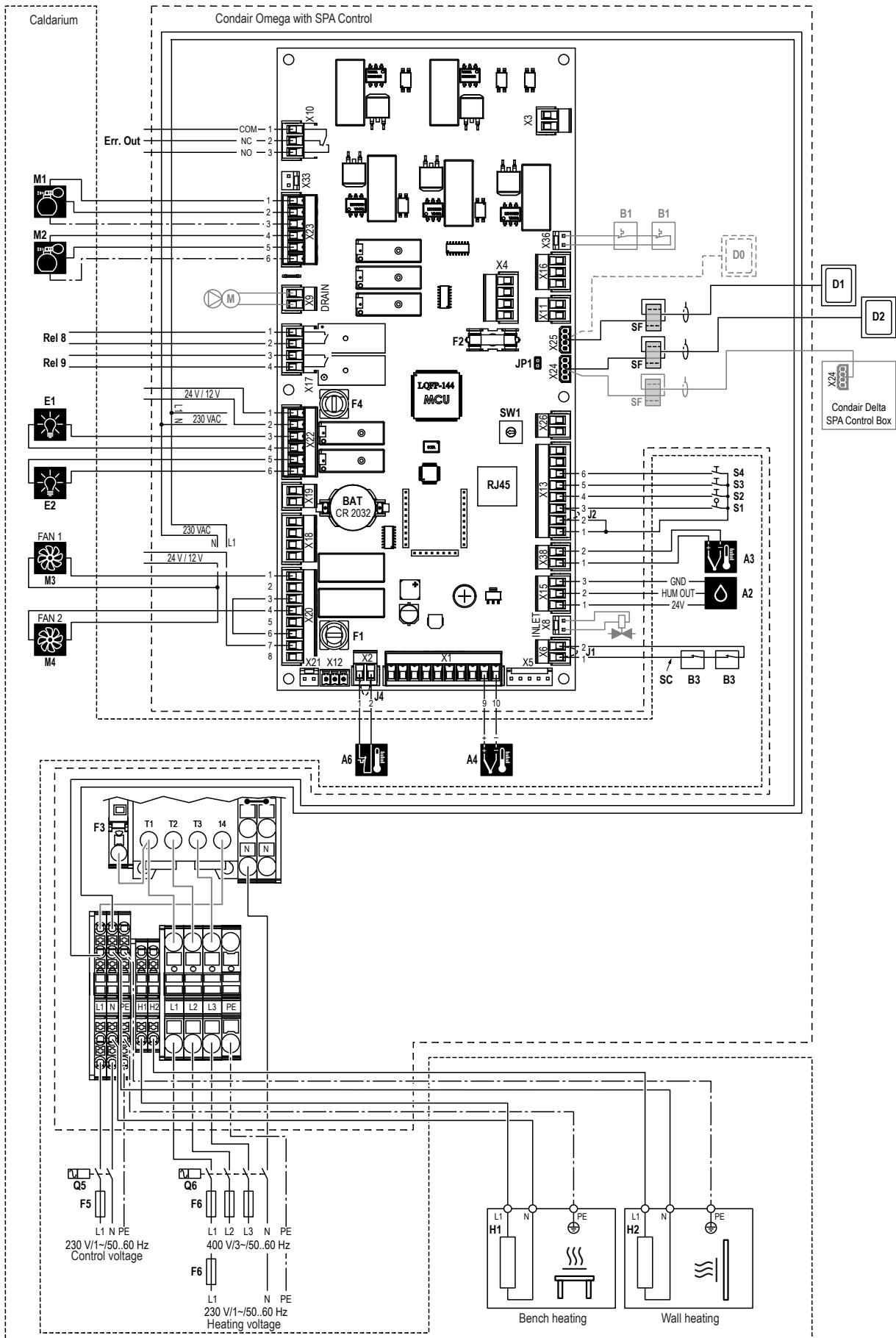

Legend wiring diagram Condair Omega with SPA control for steam bath application with optional bench heating

Symbol	Description	Remarks	Technical Details
A1	Temperature sensor with integrated overtemperature switch	Detecting of the cabin temperature	KTY, PT100, PT1000
A3	Temperature sensor Bench heating	Detecting of the bench temperature	KTY, PT100, PT1000
B1	Overtemperature switch steam tank	one or two overtemperature switches depending on the unit size	
B3	Safety devices (e.g. emergency stop)		
BAT	Backup battery SPA control board		CR2032, Lithium 3V
D0	Internal SPA display (option)	See notes in chapter 6.6.4.22	
D1/D2	External SPA display(s)		
E1	Light 1	Configurable as cleaning or color light	Maximum load: 250 V, 0.5A
E2	Light 2	Configurable as cleaning or color light	Maximum load: 250 V, 0.5A
Err.Out	Fault output		
F1	Microfuse fans		4 A, slow acting
F2	Microfuse 24 VDC external		1 A, slow acting
F3	Fuse terminal		1.6 A, slow acting
F4	Microfuse light		1 A, slow acting
F5	External fuse control voltage supply		16 A, fast acting
F6	External fuses heating voltage supply 230 V/1~/50...60 Hz	Condair Omega 2 kg/h	10 A, fast acting
		Condair Omega 4 kg/h	16 A, fast acting
		Condair Omega 6 kg/h	25 A, fast acting
		Condair Omega 8 kg/h	32 A, fast acting
	External fuses heating voltage supply 400 V/3~/50...60 Hz	Condair Omega 6 kg/h to 12 kg/h	16 A, fast acting
		Condair Omega 16 kg/h to 20 kg/h	32 A, fast acting
H1	Bench heating	 Observe safety notes in chapter 6.6.4.17!	Maximum load: 1 kW
J1	Cable bridge	Connect cable bridge to terminal block "X6", if no safety devices are connected to terminal block "X6".	
J2	Cable bridge	Connect cable bridge to terminals 2 and 3 of terminal block "X13", if no door switch is connected.	
J4	Cable bridge	Connect cable bridge to terminal block "X2", if no overtemperature switch is connected.	
JP1	Terminating resistor CAN BUS	Remove jumper, if both CAN BUS connectors are used.	
M1	Fragrance pump 1	 DANGER: 230 V output!	Maximum load: 250 V, 0.25A
M2	Fragrance pump 2	 DANGER: 230 V output!	Maximum load: 250 V, 0.25A
M3	Fan 1 (single-stage)	Control of supply and exhaust fan (configurable)	Maximum load: 250 V, 2 A
M4	Fan 2 (single-stage)	Control of supply and exhaust fan (configurable)	Maximum load: 250 V, 2 A
Rel 8	Potential-free relay contact	Used for the control of the bench heating	Maximum load: 250 V, 10A
Rel 9	Potential-free relay contact	Function freely configurable	Maximum load: 250 V, 10A
RJ45	Network connector	Network connector for the upload of software updates	
SC	Safety loop		
SF	Ferrite CAN BUS		
SW1	Rotary switch unit address	See notes in chapter 6.6.4.22	
S1	Door switch		
S2	Start-/Stop button		
S3	Light 1 button		
S4	Light 2 / Steam blast button		
Q5	External electrical isolator (all-pole disconnection) power supply		
Q6	External electrical isolator (all-pole disconnection) power supply		

6.6.3.4 Wiring diagram Condair Omega with SPA control for Caldarium application with bench and wall heating





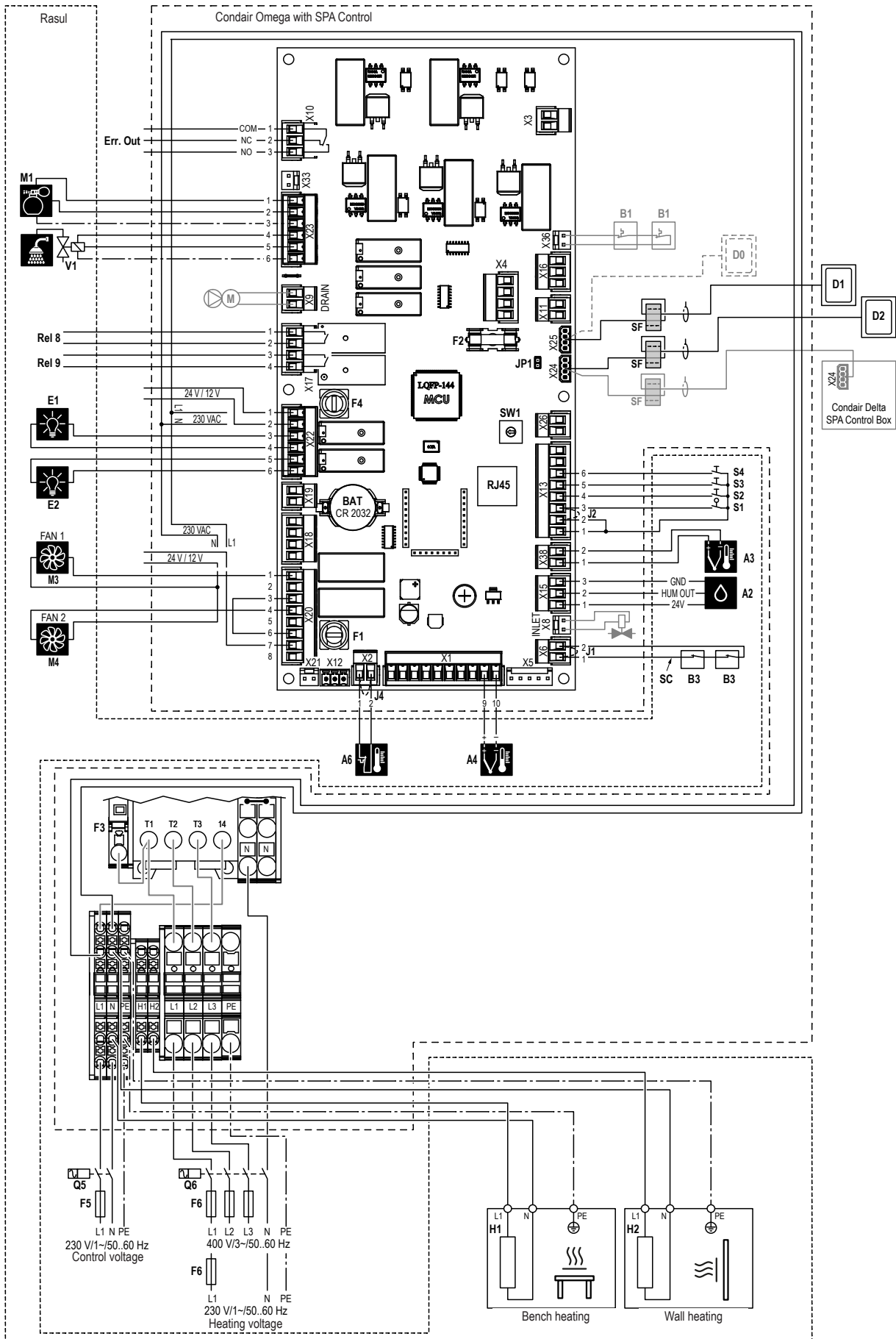

Legend wiring diagram Condair Omega with SPA control for Caldarium application with bench and wall heating

Symbol	Description	Remarks	Technical Details
A2	Humidity sensor	Caldarium	
A3	Temperature sensor Bench heating	Detecting of the bench temperature for the control of bench heating	KTY, PT100, PT1000
A4	Temperature sensor Wall heating	Detecting of the wall temperature for the control of wall heating	KTY, PT100, PT1000
A6	Cabin overtemperature switch		
B1	Overtemperature switch steam tank	one or two overtemperature switches depending on the unit size	
B3	Safety devices (e.g. emergency stop)		
BAT	Backup battery SPA control board		CR2032, Lithium 3V
D0	Internal SPA display (option)		
D1/D2	External SPA display(s)	See notes in chapter 6.6.4.22	
Err.Out	Fault output		
F1	Microfuse fans		4 A, slow acting
F2	Microfuse 24 VDC external		1 A, slow acting
F3	Fuse terminal		1.6 A, slow acting
F4	Microfuse light		1 A, slow acting
F5	External fuse control voltage supply		16 A, fast acting
F6	External fuses heating voltage supply 230 V/1~/50...60 Hz	Condair Omega 2 kg/h	10 A, fast acting
		Condair Omega 4 kg/h	16 A, fast acting
		Condair Omega 6 kg/h	25 A, fast acting
		Condair Omega 8 kg/h	32 A, fast acting
F6	External fuses heating voltage supply 400 V/3~/50...60 Hz	Condair Omega 6 kg/h to 12 kg/h	16 A, fast acting
		Condair Omega 16 kg/h to 20 kg/h	32 A, fast acting
E1	Light 1	Configurable as cleaning or color light	Maximum load: 250 V, 0.5A
E2	Light 2	Configurable as cleaning or color light	Maximum load: 250 V, 0.5A
H1	Bench heating	 Observe safety notes in chapter 6.6.4.17!	Maximum load: 1 kW
H2	Wall heating	 Observe safety notes in chapter 6.6.4.17!	Maximum load: 1 kW
J1	Cable bridge	Connect cable bridge to terminal block "X6", if no safety devices are connected to terminal block "X6".	
J2	Cable bridge	Connect cable bridge to terminals 2 and 3 of terminal block "X13", if no door switch is connected.	
J4	Cable bridge	Connect cable bridge to terminal block "X2", if no overtemperature switch "A6".	
JP1	Terminating resistor CAN BUS	Remove jumper, if both CAN BUS connectors are used.	
M1	Fragrance pump 1	 DANGER: 230 V output!	Maximum load: 250 V, 0.25A
M2	Fragrance pump 2	 DANGER: 230 V output!	Maximum load: 250 V, 0.25A
M3	Fan 1 (single-stage)	Control of supply and exhaust fan (configurable)	Maximum load: 250 V, 2 A
M4	Fan 2 (single-stage)	Control of supply and exhaust fan (configurable)	Maximum load: 250 V, 2 A
Rel 8	Potential-free relay contact	Used for the control of the bench heating	Maximum load: 250 V, 10A
Rel 9	Potential-free relay contact	Used for wall heating	Maximum load: 250 V, 10A
RJ45	Network connector	Network connector for the upload of software updates	
SC	Safety loop		
SF	Ferrite CAN BUS		
SW1	Rotary switch unit address	See notes in chapter 6.6.4.22	
S1	Door switch		
S2	Start-/Stop button		
S3	Light 1 button		
S4	Light 2 / Steam blast button		
Q5	External electrical isolator (all-pole disconnection) power supply		
Q6	External electrical isolator (all-pole disconnection) power supply		



6.6.3.5 Wiring diagram Condair Omega with SPA control for Rasul application with bench and wall heating



Legend wiring diagram Condair Omega with SPA control for Rasul application with bench and wall heating

Symbol	Description	Remarks	Technical Details
A2	Humidity sensor	Rasul	
A3	Temperature sensor Bench heating	Detecting of the bench temperature for the control of bench heating	KTY, PT100, PT1000
A4	Temperature sensor Wall heating	Detecting of the wall temperature for the control of wall heating	KTY, PT100, PT1000
A6	Cabin overtemperature switch		
B1	Overtemperature switch steam tank	one or two overtemperature switches depending on the unit size	
B3	Safety devices (e.g. emergency stop)		
BAT	Backup battery SPA control board		CR2032, Lithium 3V
D0	Internal SPA display (option)		
D1/D2	External SPA display(s)	See notes in chapter 6.6.4.22	
Err.Out	Fault output		
F1	Microfuse fans		4 A, slow acting
F2	Microfuse 24 VDC external		1 A, slow acting
F3	Fuse terminal		1.6 A, slow acting
F4	Microfuse light		1 A, slow acting
F5	External fuse control voltage supply		16 A, fast acting
F6	External fuses heating voltage supply 230 V/1~/50...60 Hz	Condair Omega 2 kg/h	10 A, fast acting
		Condair Omega 4 kg/h	16 A, fast acting
		Condair Omega 6 kg/h	25 A, fast acting
		Condair Omega 8 kg/h	32 A, fast acting
External fuses heating voltage supply 400 V/3~/50...60 Hz	Condair Omega 6 kg/h to 12 kg/h	16 A, fast acting	
	Condair Omega 16 kg/h to 20 kg/h	32 A, fast acting	
E1	Light 1	Configurable as cleaning or color light	Maximum load: 250 V, 0.5A
E2	Light 2	Configurable as cleaning or color light	Maximum load: 250 V, 0.5A
H1	Bench heating	 Observe safety notes in chapter 6.6.4.17!	Maximum load: 1 kW
H2	Wall heating	 Observe safety notes in chapter 6.6.4.17!	Maximum load: 1 kW
J1	Cable bridge	Connect cable bridge to terminal block "X6", if no safety devices are connected to terminal block "X6".	
J2	Cable bridge	Connect cable bridge to terminals 2 and 3 of terminal block "X13", if no door switch is connected.	
J4	Cable bridge	Connect cable bridge to terminal block "X2", if no overtemperature switch "A6".	
JP1	Terminating resistor CAN BUS	Remove jumper, if both CAN BUS connectors are used.	
M1	Fragrance pump 1	 DANGER: 230 V output!	Maximum load: 250 V, 0.25A
M3	Fan 1 (single-stage)	Control of supply and exhaust fan (configurable)	Maximum load: 250 V, 2 A
M4	Fan 2 (single-stage)	Control of supply and exhaust fan (configurable)	Maximum load: 250 V, 2 A
Rel 8	Potential-free relay contact	Used for the control of the bench heating	Maximum load: 250 V, 10A
Rel 9	Potential-free relay contact	Used for wall heating	Maximum load: 250 V, 10A
RJ45	Network connector	Network connector for the upload of software updates	
SC	Safety loop		
SF	Ferrite CAN BUS		
SW1	Rotary switch unit address	See notes in chapter 6.6.4.22	
S1	Door switch		
S2	Start-/Stop button		
S3	Light 1 button		
S4	Light 2 / Steam blast button		
Q5	External electrical isolator (all-pole disconnection) power supply		
Q6	External electrical isolator (all-pole disconnection) power supply		
V1	Valve cabin shower	 DANGER: 230 V output!	Maximum load: 250 V, 0.25A



Legend wiring diagram Condair Omega 2 kg/h with SPA control for bio sauna application, sauna heating controlled internally

Symbol	Description	Remarks	Technical details
A1	Temperature sensor with integrated over-temperature switch	Detecting of the cabin temperature	KTY, PT100, PT1000
A2	Humidity sensor	Bio sauna	
B1	Overtemperature switch steam tank	one or two overtemperature switches depending on the unit size	
B3	Safety devices (e.g. emergency stop)		
B4	Safety device sauna heating	e.g. switch protection cover sauna heater	
BAT	Backup battery SPA control board		CR2032, Lithium 3V
D0	Internal SPA display (option)	See notes in chapter 6.6.4.22	
D1/D2	External SPA display(s)		
E1	Light 1	Configurable as cleaning or color light	Maximum load: 250 V, 0.5A
E2	Light 2	Configurable as cleaning or color light	Maximum load: 250 V, 0.5A
Err.Out	Fault output		
F1	Microfuse fans		4 A, slow acting
F2	Microfuse 24 VDC external		1 A, slow acting
F3	Fuse terminal		1.6 A, slow acting
F4	Microfuse light		1 A, slow acting
F5	External fuse 400 V/3~/50..60 Hz sauna heater voltage supply		16 A, fast acting
F6	External fuse heating voltage supply 230 V/1~/50..60 Hz		10 A, fast acting
H4	Sauna heater	 Observe safety notes in chapter 6.6.4.18!	Maximum load: 9 kW
J1	Cable bridge	Connect cable bridge to terminal block "X6", if no safety devices are connected to terminal block "X6".	
J2	Cable bridge	Connect cable bridge to terminals 2 and 3 of terminal block "X2", if no door switch is connected.	
J4	Cable bridge	Connect cable bridge to terminal block "X2", if no over-temperature switch is connected.	
JP1	Terminating resistor CAN BUS	Remove jumper, if both CAN BUS connectors are used.	
M1	Fragrance pump 1	 DANGER: 230 V output!	Maximum load: 250 V, 0.25A
M2	Fragrance pump 2	 DANGER: 230 V output!	Maximum load: 250 V, 0.25A
M3	Fan 1 (single-stage)	Control of supply and exhaust fan (configurable)	Maximum load: 250 V, 2 A
M4	Fan 2 (single-stage)	Control of supply and exhaust fan (configurable)	Maximum load: 250 V, 2 A
RJ45	Network connector	Network connector for the upload of software updates	
Rel 8	Potential-free relay contact	Function freely configurable	Maximum load: 250 V, 10A
Rel 9	Potential-free relay contact	Function freely configurable	Maximum load: 250 V, 10A
SC	Safety loop		
SF	Ferrite CAN BUS		
SW1	Rotary switch unit address	See notes in chapter 6.6.4.22	
S1	Door switch		
S2	Start-/Stop button		
S3	Light 1 button		
S4	Light 2 / Steam blast button		
Q5	External electrical isolator (all-pole disconnection) power supply		
Q6	External electrical isolator (all-pole disconnection) power supply		

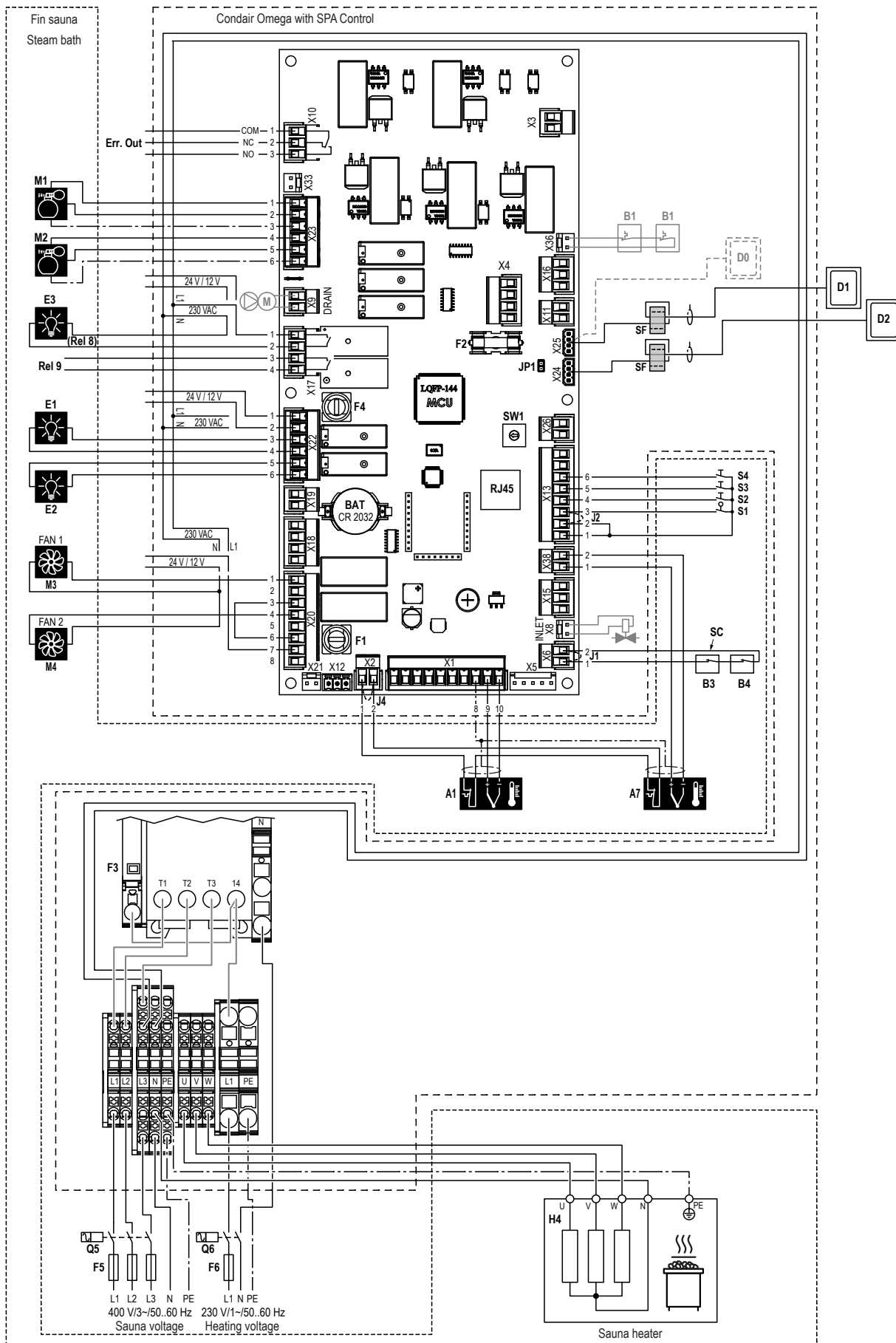
6.6.3.7 Wiring diagram Condair Omega 8 kg/h with SPA control for dual cabin application (Fin sauna / Steam bath), sauna heating controlled internally





Wiring diagram Condair Omega 8 kg/h with SPA control for dual cabin application (Fin sauna / Steam bath), sauna heating controlled internally

Symbol	Description	Remarks	Technical Details
A1	Temperature sensor with integrated over-temperature switch	Cabin temperature sensor with integrated over-temperature switch for steam bath cabin	KTY, PT100, PT1000
A7	Temperature sensor with integrated over-temperature switch	Cabin temperature sensor with integrated over-temperature switch for sauna cabin	KTY, PT100, PT1000
B1	Overtemperature switch steam tank	one or two overtemperature switches depending on the unit size	
B3	Safety devices (e.g. emergency stop)		
B4	Safety device sauna heating	e.g. switch protection cover sauna heater	
BAT	Backup battery SPA control board		CR2032, Lithium 3V
D0	Internal SPA display (option)		
D1/D2	External SPA display(s)	See notes in chapter 6.6.4.22	
E1	Light 1	Combined cleaning light (can be configured for one of the two cabins). Light 1 can be controlled via button "S3" or via the SPA display.	Maximum load: 250 V, 0.5A
E2	Light 2	Color light steam bath cabin	Maximum load: 250 V, 0.5A
E3 (Rel 8)	Light 3	Color light sauna cabin	Maximum load: 250 V, 10A
Err.Out	Fault output		
F1	Microfuse fans		4 A, slow acting
F2	Microfuse 24 VDC external		1 A, slow acting
F3	Fuse terminal		1.6 A, slow acting
F4	Microfuse light		1 A, slow acting
F5	External fuse 400 V/3~/50..60 Hz sauna heater voltage supply		16 A, fast acting
F6	External fuse heating voltage supply 230 V/1~/50..60 Hz		32 A, fast acting
H4	Sauna heater	 Observe safety notes in chapter 6.6.4.18!	Maximum load: 9 kW
J1	Cable bridge	Connect cable bridge to terminal block "X6", if no safety devices are connected to terminal block "X6".	
J2	Cable bridge	Connect cable bridge to terminals 2 and 3 of terminal block "X13", if no door switch is connected.	
J4	Cable bridge	Connect cable bridge to terminal block "X2", if no overtemperature switch is connected.	
JP1	Terminating resistor CAN BUS	Remove jumper, if both CAN BUS connectors are used.	
M1	Fragrance pump 1	 DANGER: 230 V output!	Maximum load: 250 V, 0.25A
M2	Fragrance pump 2	 DANGER: 230 V output!	Maximum load: 250 V, 0.25A
M3	Fan 1 (single-stage)	Fan steam bath cabin	Maximum load: 250 V, 2 A
M4	Fan 2 (single-stage)	Fan sauna cabin	Maximum load: 250 V, 2 A
Rel 9	Potential-free relay contact	The potential free contact can be used for one of the two cabins.	Maximum load: 250 V, 10A
RJ45	Network connector	Network connector for the upload of software updates	
SC	Safety loop	Remove jumper, if both CAN BUS connectors are used.	
SF	Ferrite CAN BUS		
SW1	Rotary switch unit address	Always set to Pos. "0"	
S1	Door switch	Door switch steam bath cabin	
S2	Start-/Stop button	Start-/Stop button steam bath cabin	
S3	Light 1 button	Light 1 button for combined cleaning light	
S4	Start-/Stop button	Start-/Stop button sauna cabin	
Q5	External electrical isolator (all-pole disconnection) power supply		
Q6	External electrical isolator (all-pole disconnection) power supply		

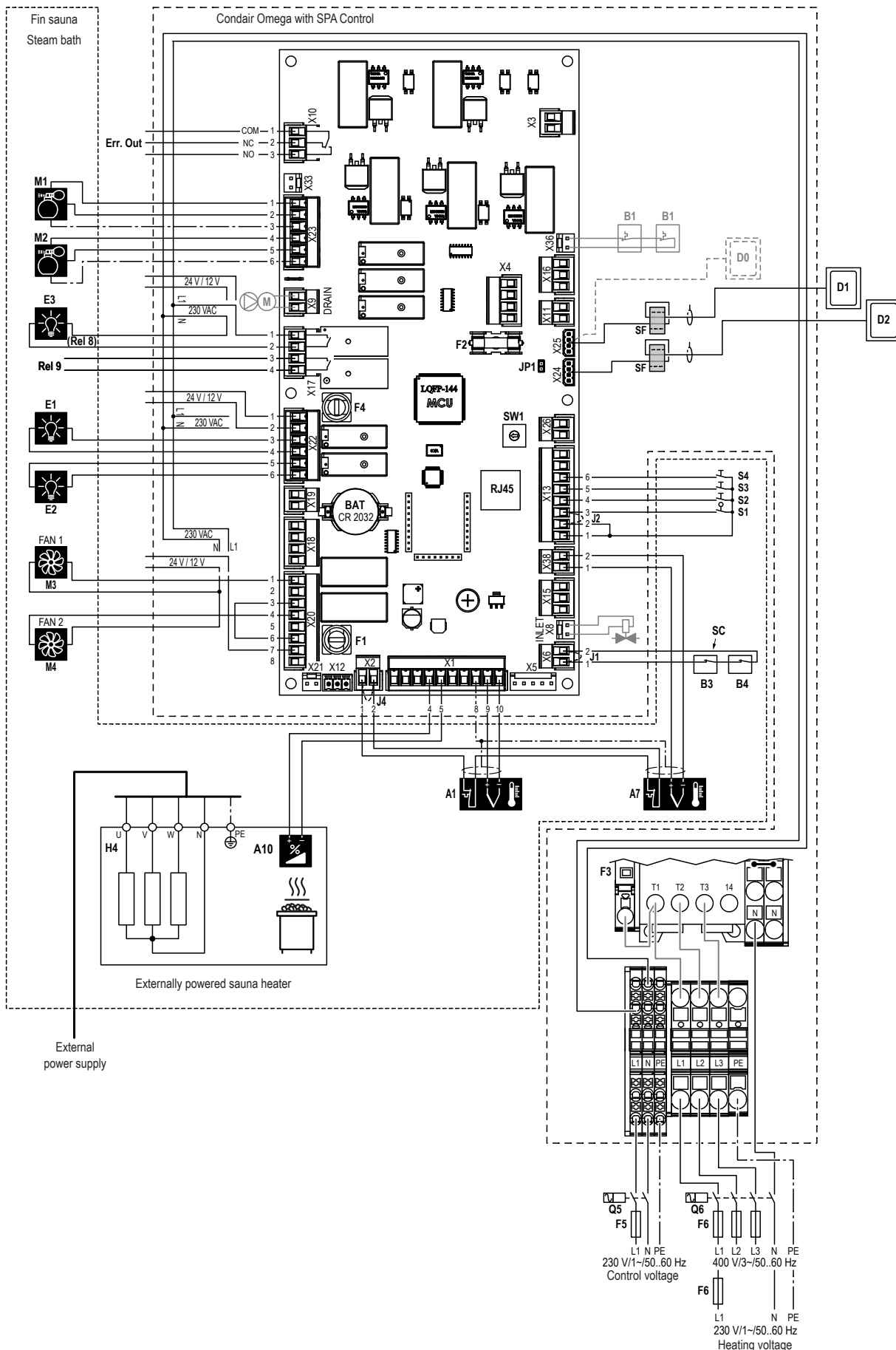
6.6.3.8 Wiring diagram Condair Omega 8 kg/h with SPA control for dual cabin application (Fin sauna / steam bath) with an externally powered sauna heater



Wiring diagram Condair Omega 8 kg/h with SPA control for dual cabin application (Fin sauna / steam bath) with an externally powered sauna heater

Symbol	Description	Remarks	Technical Details
A1	Temperature sensor with integrated over-temperature switch	Cabin temperature sensor with integrated over-temperature switch for steam bath cabin	KTY, PT100, PT1000
A7	Temperature sensor with integrated over-temperature switch	Cabin temperature sensor with integrated over-temperature switch for sauna cabin	KTY, PT100, PT1000
A10	Demand signal sauna heater	Demand signal for the control of the heating of the externally powered sauna heater	0-10 V
B1	Overtemperature switch steam tank	one or two overtemperature switches depending on the unit size	
B3	Safety devices (e.g. emergency stop)		
B4	Safety device sauna heating	e.g. switch protection cover sauna heater	
BAT	Backup battery SPA control board		CR2032, Lithium 3V
D0	Internal SPA display (option)	See notes in chapter 6.6.4.22	
D1/D2	External SPA display(s)		
E1	Light 1	Combined cleaning light (can be configured for one of the two cabins). Light 1 can be controlled via button "S3" or via the SPA display.	Maximum load: 250 V, 0.5A
E2	Light 2	Color light steam bath cabin	Maximum load: 250 V, 0.5A
E3 (Rel 8)	Light 3	Color light sauna cabin	Maximum load: 250 V, 10A
Err.Out	Fault output		
F1	Microfuse fans		4 A, slow acting
F2	Microfuse 24 VDC external		1 A, slow acting
F3	Fuse terminal		1.6 A, slow acting
F4	Microfuse light		1 A, slow acting
F5	External fuse control voltage supply		10 A, fast acting
F6	External fuses heating voltage supply 230 V/1~/50...60 Hz	Condair Omega 8 kg/h	32 A, fast acting
	External fuses heating voltage supply 400 V/3~/50...60 Hz	Condair Omega 8 kg/h	16 A, fast acting
H4	Sauna heater	 Observe safety notes in chapter 6.6.4.18!	Maximum load: 9 kW
J1	Cable bridge	Connect cable bridge to terminal block "X6", if no safety devices are connected to terminal block "X6".	
J2	Cable bridge	Connect cable bridge to terminals 2 and 3 of terminal block "X13", if no door switch is connected.	
J4	Cable bridge	Connect cable bridge to terminal block "X2", if no overtemperature switch is connected.	
JP1	Terminating resistor CAN BUS	Remove jumper, if both CAN BUS connectors are used.	
M1	Fragrance pump 1	 DANGER: 230 V output!	Maximum load: 250 V, 0.25A
M2	Fragrance pump 2	 DANGER: 230 V output!	Maximum load: 250 V, 0.25A
M3	Fan 1 (single-stage)	Control of supply and exhaust fan (configurable)	Maximum load: 250 V, 2 A
M4	Fan 2 (single-stage)	Control of supply and exhaust fan (configurable)	Maximum load: 250 V, 2 A
Rel 9	Potential-free relay contact	The potential free contact can be used for one of the two cabins.	Maximum load: 250 V, 10A
RJ45	Network connector	Network connector for the upload of software updates	
SC	Safety loop		
SF	Ferrite CAN BUS		
SW1	Rotary switch unit address	Always set to Pos. "0"	
S1	Door switch	Door switch steam bath cabin	
S2	Start-/Stop button	Start-/Stop button steam bath cabin	
S3	Light 1 button	Light 1 button for combined cleaning light	
S4	Start-/Stop button	Start-/Stop button sauna cabin	
Q5	External electrical isolator (all-pole disconnection) power supply		
Q6	External electrical isolator (all-pole disconnection) power supply		

6.6.4 Installation work external connections

6.6.4.1 Connection of switch "S1" and buttons "S2" to "S4"

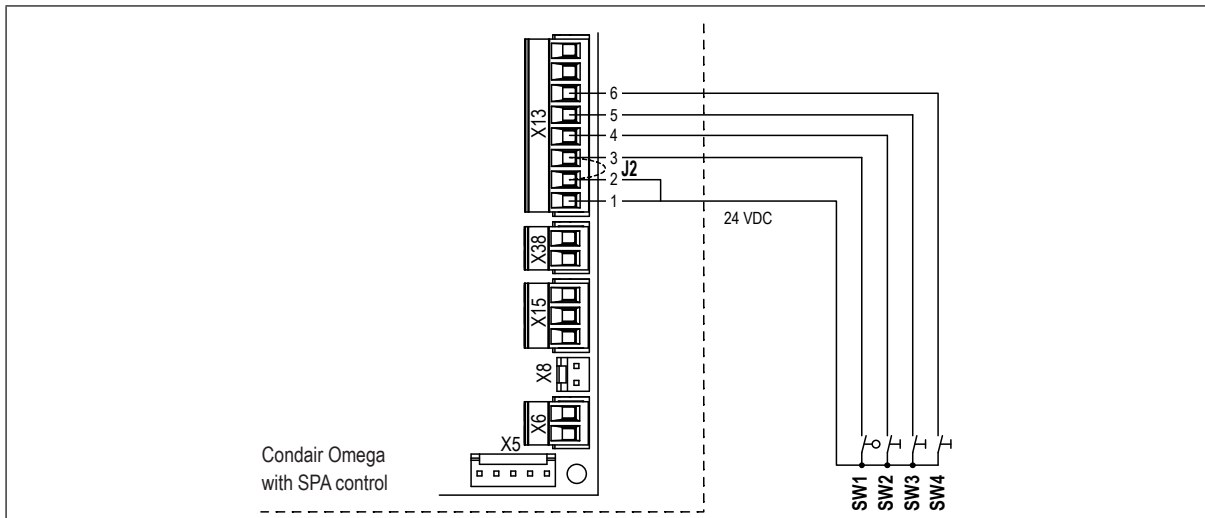

The switch "S1" (door switch) and the buttons "S2" (steam bath On/Off), "S3" (light 1 On/Off) and "S4" (light 2 or Steam blast On/Off) for manual switching of the respective components are to be connected to the corresponding terminals of terminal block "X13" on the SPA control board inside control compartment of the Condair Omega according to the wiring diagram. The switch and the buttons are operated with 24 VDC.

Note: If no door switch "S1" is connected, a wire jumper "J2" must be connected to terminals "2" and "3" of the terminal block "X13"

Note: If the steam blast function is activated, "S4" serves as start button for a steam blast. If the function is deactivated, light 2 can be switched On and Off.

Note: With dual cabin applications for small cabins (Fin sauna / steam bath), the switch "S1" and the buttons "S2" to "S4" are used with a different assignment. Refer to the notes in the legends of corresponding wiring diagram in [chapter 6.6.3.7](#) or [chapter 6.6.3.8](#).

The cross-section of the connection cable must comply with the applicable local regulations.

6.6.4.2 Connection of the temperature sensor "A1" for monitoring the cabin temperature

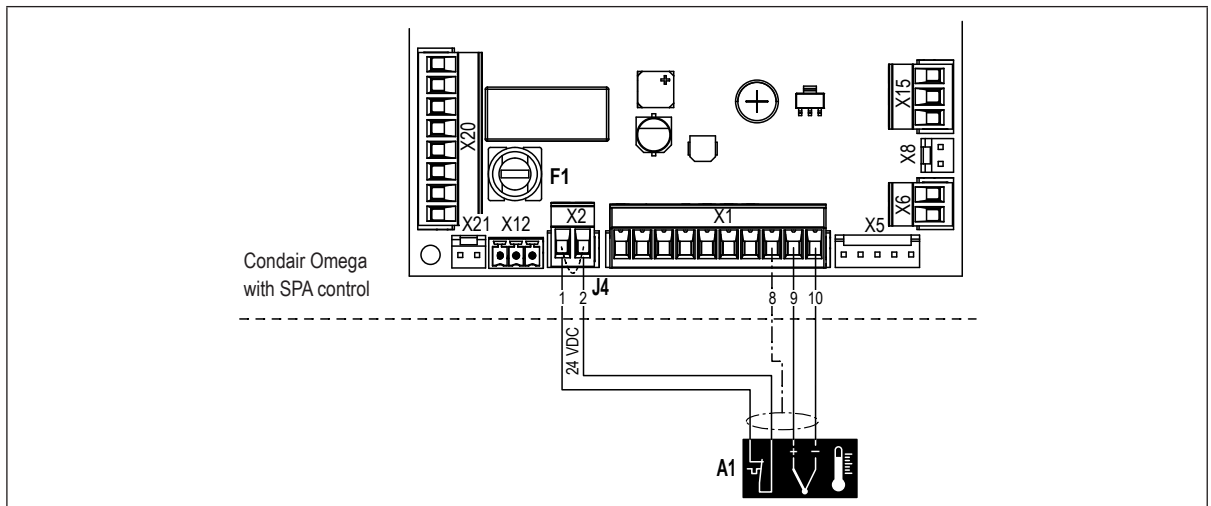

The temperature sensor is connected to terminals "9" (+) and "10" (-) of terminal block "X1" on the SPA control board inside the control compartment of the Condair Omega. The following sensors are supported: KTY, PT100 and PT1000.

The overtemperature switch (24 VDC) for monitoring the maximum cabin temperature is connected to terminals "1" and "2" of terminal block "X2" on the SPA control board inside the control compartment of the Condair Omega. If installed, remove wire jumper "J4" first.

Note: Use only certified temperature sensors from Condair which are available as Wellness accessory.



CAUTION! Do not apply any external voltage to the contacts "1" and "2".

For the connection of the temperature sensor and the overtemperature switch we recommend the use of a shielded cable. The shield of the sensor cable is connected to terminal "8" of terminal block "X1" on the SPA control board inside the control compartment of the Condair Omega.

Note: The temperature sensor with integrated overtemperature switch for the steam cabin must be installed in a suitable location (not in the immediate vicinity of the steam outlet) in the steam cabin. The temperature sensor (oven sensor) for the sauna heater must be installed above the sauna heater. For the placement and connection of the temperature sensor, please observe the instructions in the separate installation instructions for this product.

6.6.4.3 Connection of the humidity sensor "A2"

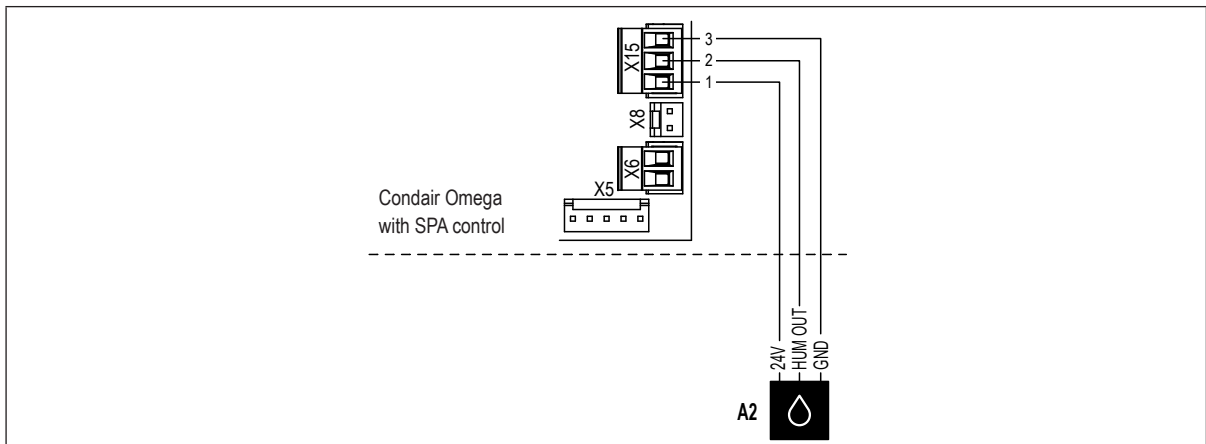

The humidity sensor is connected according to the wiring diagram to terminals "1" (24V), "2" (HUM OUT) and "3" (GND) of terminal block "X15" on the SPA control board inside the control compartment of the Condair Omega.

The following control signals are supported: 0-5V, 1-5V, 0-10V, 2-10V, 0-20V, 0-16V, 3-16V, 0-20mA, 4-20mA, On/Off and 0-4V.

6.6.4.4 Connection of the temperature sensor "A3" of the bench heating

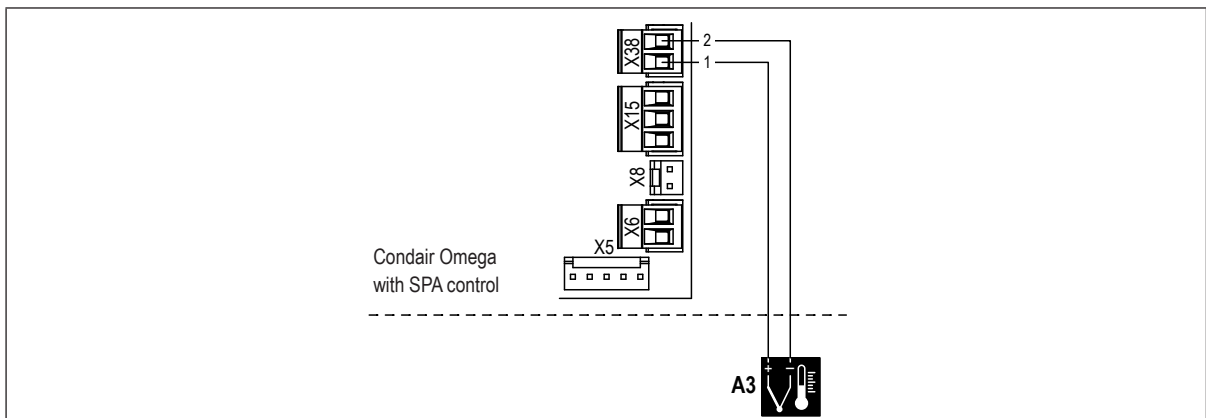

The temperature sensor "A3" for detecting the temperature of the bench heating is connected according to the wiring diagram to the terminals "1" (+) and "2" (-) of the terminal block "X38" on the SPA control board inside the control compartment of the Condair Omega.

The following sensors are supported: KTY, PT100 and PT1000.

6.6.4.5 Connection of the temperature sensor "A4" of the wall heating

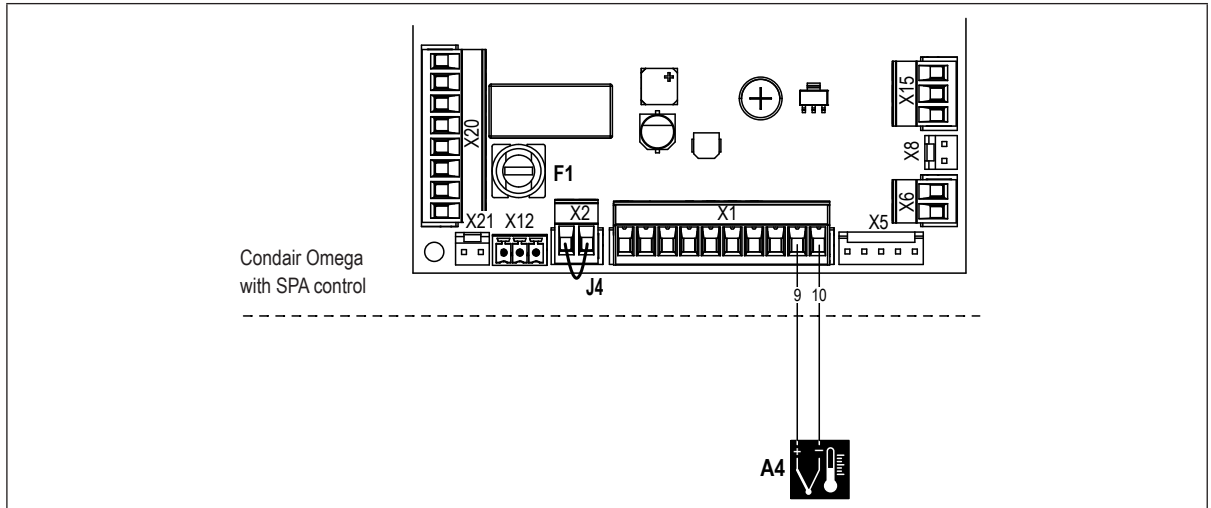

The temperature sensor "A4" for detecting the temperature of the wall heating is connected according to the wiring diagram to the terminals "1" (+) and "2" (-) of the terminal block "X38" on the SPA control board inside the control compartment of the Condair Omega.

The following sensors are supported: KTY, PT100 and PT1000.

6.6.4.6 Connection of the cabin over-temperature switch "A6"

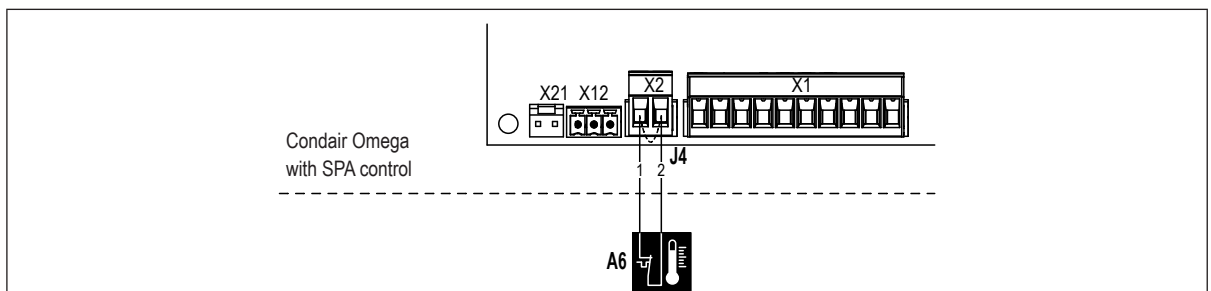

The cabin over-temperature switch "A6" is connected according to the wiring diagram to the terminals "1" (+) and "2" (-) of the terminal block "X2" on the SPA control board inside the control compartment of the Condair Omega. If installed, remove wire jumper "J4" first.

Note: Use only certified overtemperature sensors, which do not reset automatically.



CAUTION! Do not apply any external voltage to the contacts "1" and "2".

Note: The terminal block "X2" is operated with 24 VDC. Only connect approved 24 VDC overtemperature switches to terminal block "X2". In the event of a fault, the safety contact is opened, thus interrupting the safety chain.

6.6.4.7 Connection of the temperature sensors "A1" and "A7" for the temperature control of small cabins for dual cabin application

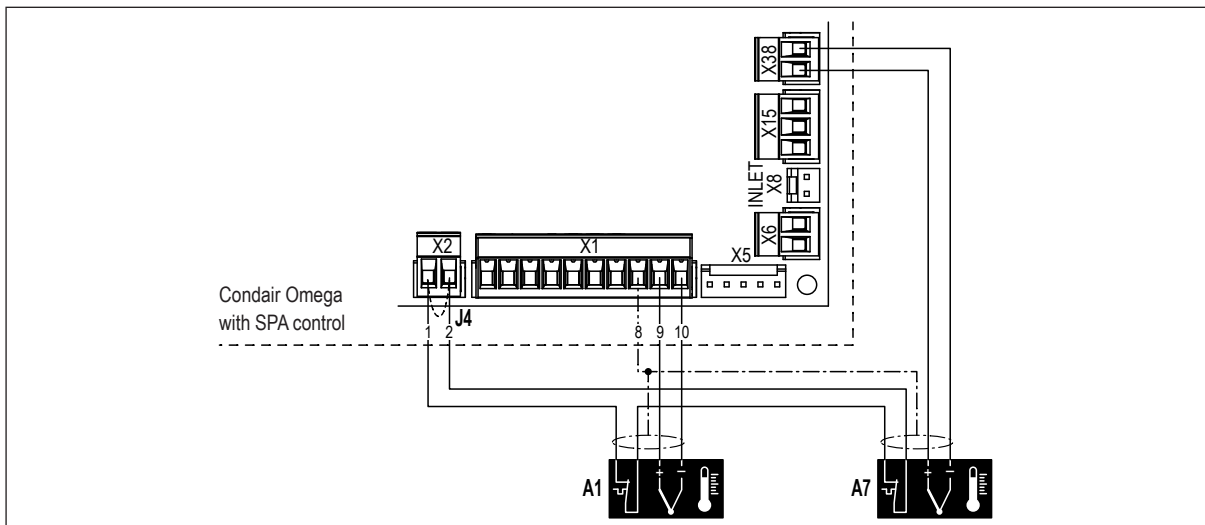

The temperature sensors "A1" and "A7" are connected according to the wiring diagram to the terminals "9" (+) and "10" (-) of the terminal block "X1" on the SPA control board inside the control compartment of the Condair Omega.

The following sensors are supported: KTY, PT100 and PT1000.

The overtemperature switches (24 VDC) for monitoring the maximum cabin temperatures are connected to terminals "1" and "2" of terminal block "X2" on the SPA control board inside the control compartment of the Condair Omega. If installed, remove wire jumper "J4" first.

Note: Use only certified temperature sensors from Condair which are available as Wellness accessory.



CAUTION! Do not apply any external voltage to the contacts "1" and "2".

For the connection of the temperature sensors and the overtemperature switches we recommend the use of shielded cables. The shields of the sensor cables are connected to terminal "8" of terminal block "X1" on the SPA control board inside the control compartment of the Condair Omega.

Note: The temperature sensor for the steam cabin must be installed in a suitable location (not in the immediate vicinity of the steam outlet or the sauna heater) in the steam cabin. The temperature sensor (oven sensor) for the sauna must be installed above the sauna heater.

For the placement and connection of the temperature sensors, please observe the instructions in the separate installation instructions of the corresponding product.

6.6.4.8 Connection of the temperature sensor "A8"

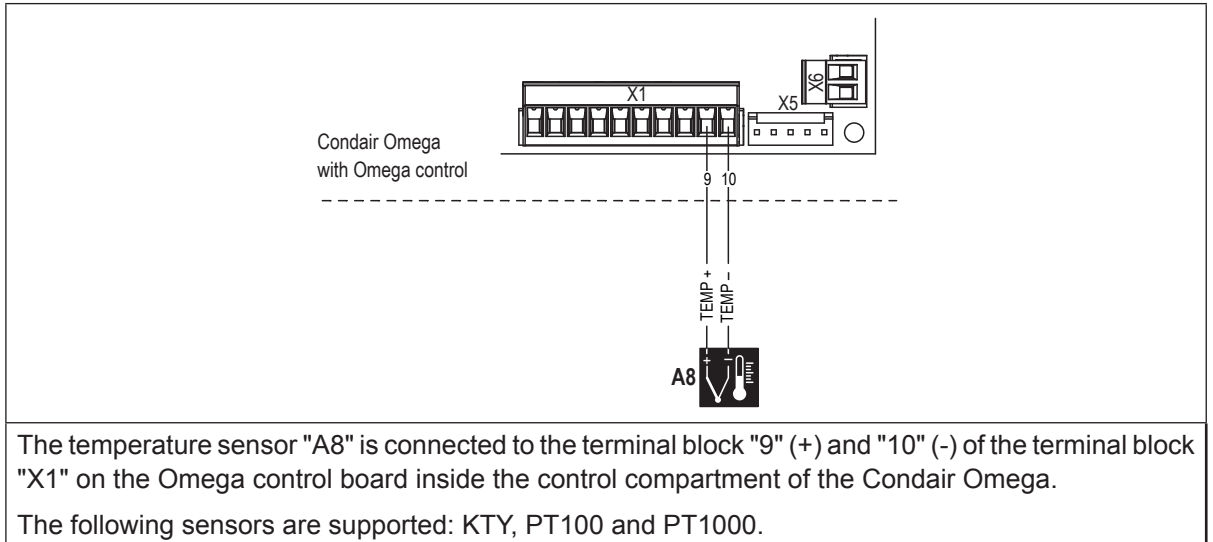

6.6.4.9 Connecting the signal cable of an external controller "A9"

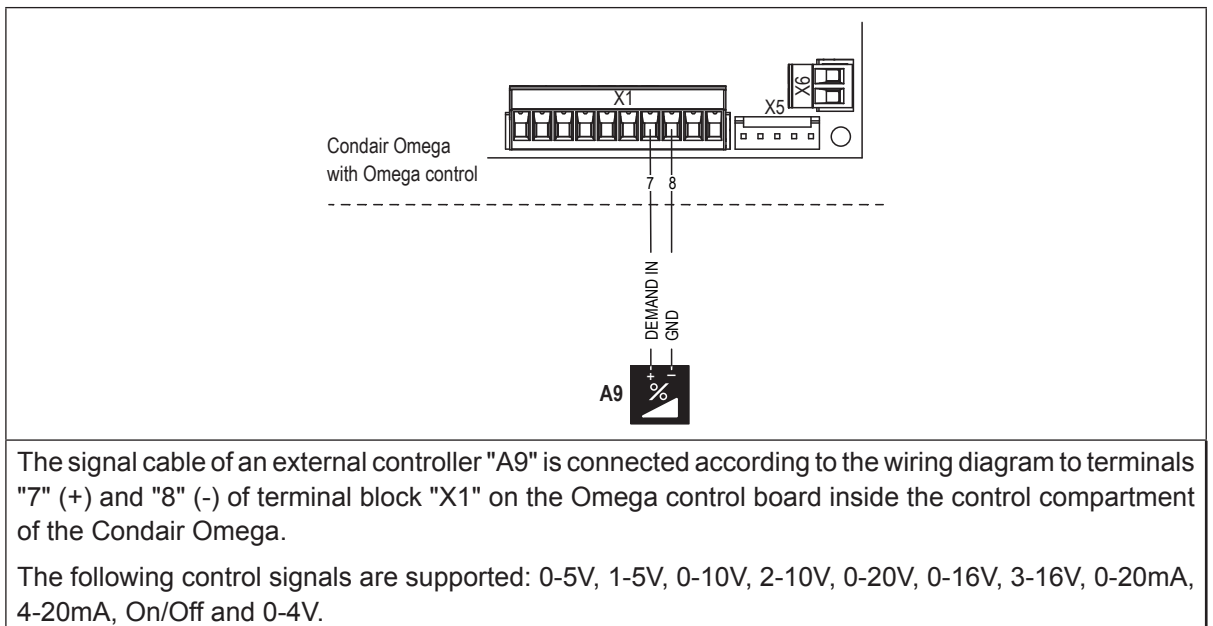

6.6.4.10 Connection of the demand signal "A10" for controlling the heating of an externally powered sauna heater

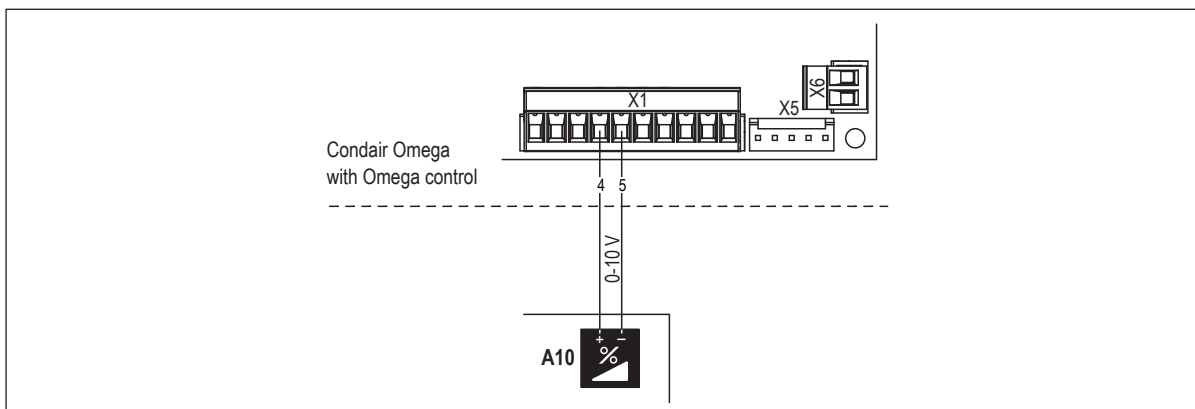

The demand signal "A10" for controlling an externally powered sauna heater is connected according to the wiring diagram to terminals "4" (+) and "5" (-) of the demand signal output of terminal block "X1" on the Omega control board inside the control compartment of the Condair Omega.

The output signal for the demand signal is 0-10 V and corresponds to a demand range of 0-100%.

6.6.4.11 Connection of the On/Off button "B2"

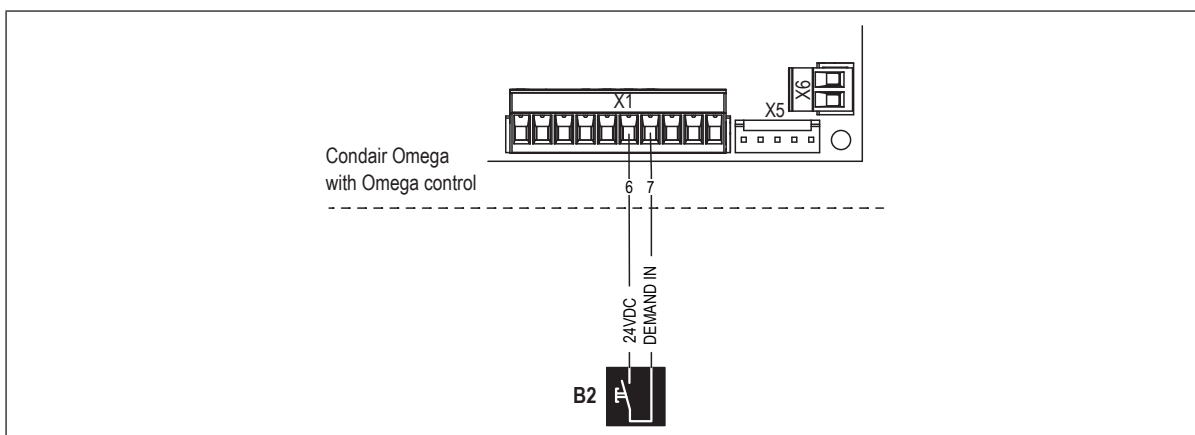

An On/Off button "B2" for the steam shower operation is connected according to the wiring diagram to the terminals "6" and "7" of the terminal block "X1" on the Omega control board inside the control compartment of the Condair Omega.

Note: The On/Off button is required to manually turn the steam shower on and off and is only enabled on the Condair Omega with Omega control.

6.6.4.12 Connection of fragrance pumps "M1" and "M2" (230 VAC)

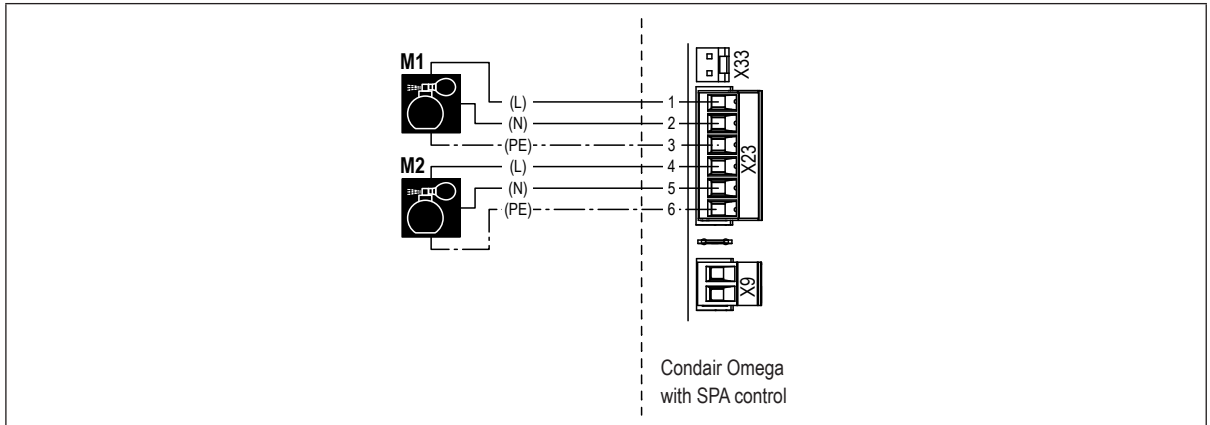

The fragrance pumps "M1" and "M2" are connected according to the wiring diagram to the corresponding terminals of the terminal block "X23" on the SPA control board inside the control compartment of the Condair Omega.



DANGER: The output voltage of the terminals is 230 VAC!

The cross-section of the connecting cables must comply with the applicable local regulations.

The maximum load is: 250 V, 0.25 A

6.6.4.13 Connecting the cabin light "E1" and "E2"

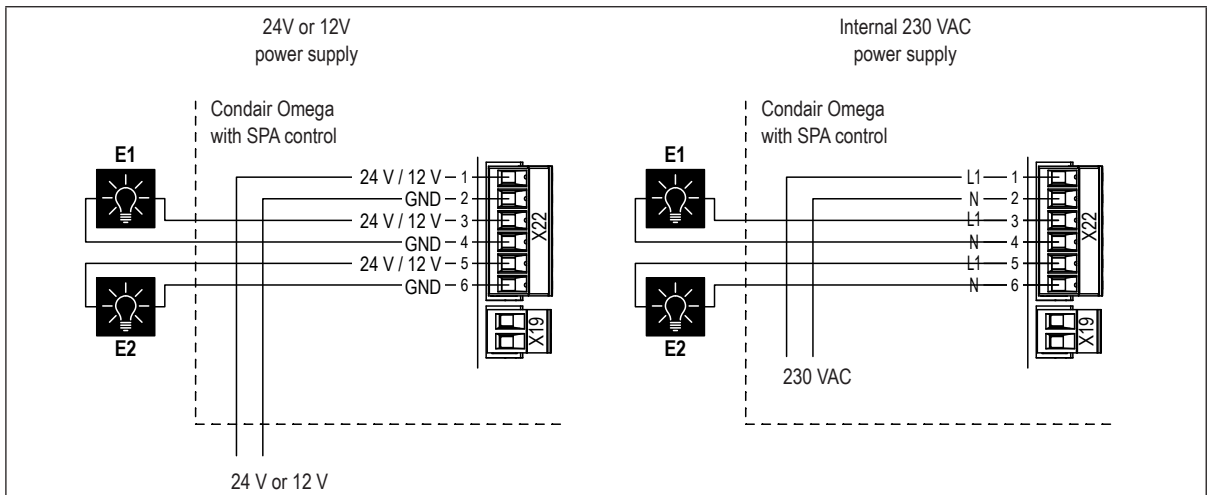

The cabin light "E1" (light 1) and "E2" (light 2) are connected according to the wiring diagram to the corresponding terminals of terminal block "X22" on the SPA control board inside the control compartment of the Condair Omega.

Depending on the lamps used, the cabin light is supplied either via the internal 230 VAC power supply or an external 24 V or 12 V power supply.

The cross-section of the connecting cables must comply with the applicable local regulations.

The maximum load is: 250 V, 0.5 A

6.6.4.14 Connection of color light "E3" for the sauna cabin for dual cabin application of small cabins

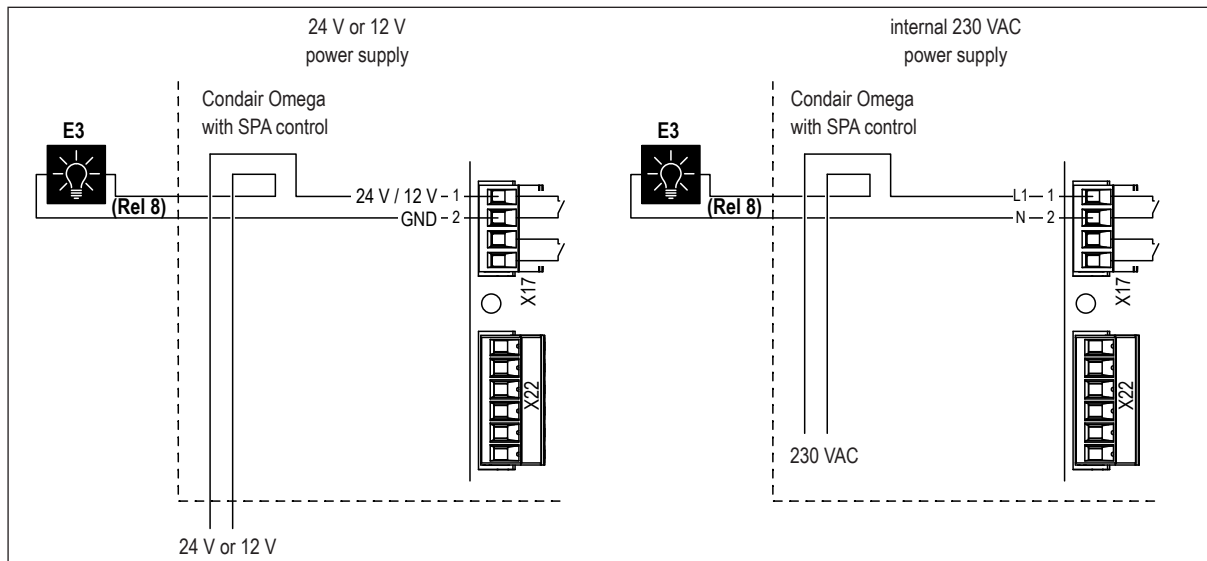

The color light "E3" for the sauna cabin for dual cabin applications for small cabins is connected according to the wiring diagram to the corresponding terminals of the terminal block "X17" on the SPA control board inside the control compartment of the Condair Omega.

Depending on the lamps used, the color light is supplied either via the internal 230 VAC power supply or an external 24 V or 12 V power supply.

The cross-section of the connecting cables must comply with the applicable local regulations.

The maximum load is: 250 V, 0.5 A

6.6.4.15 Connection of the fans "M3" and "M4"

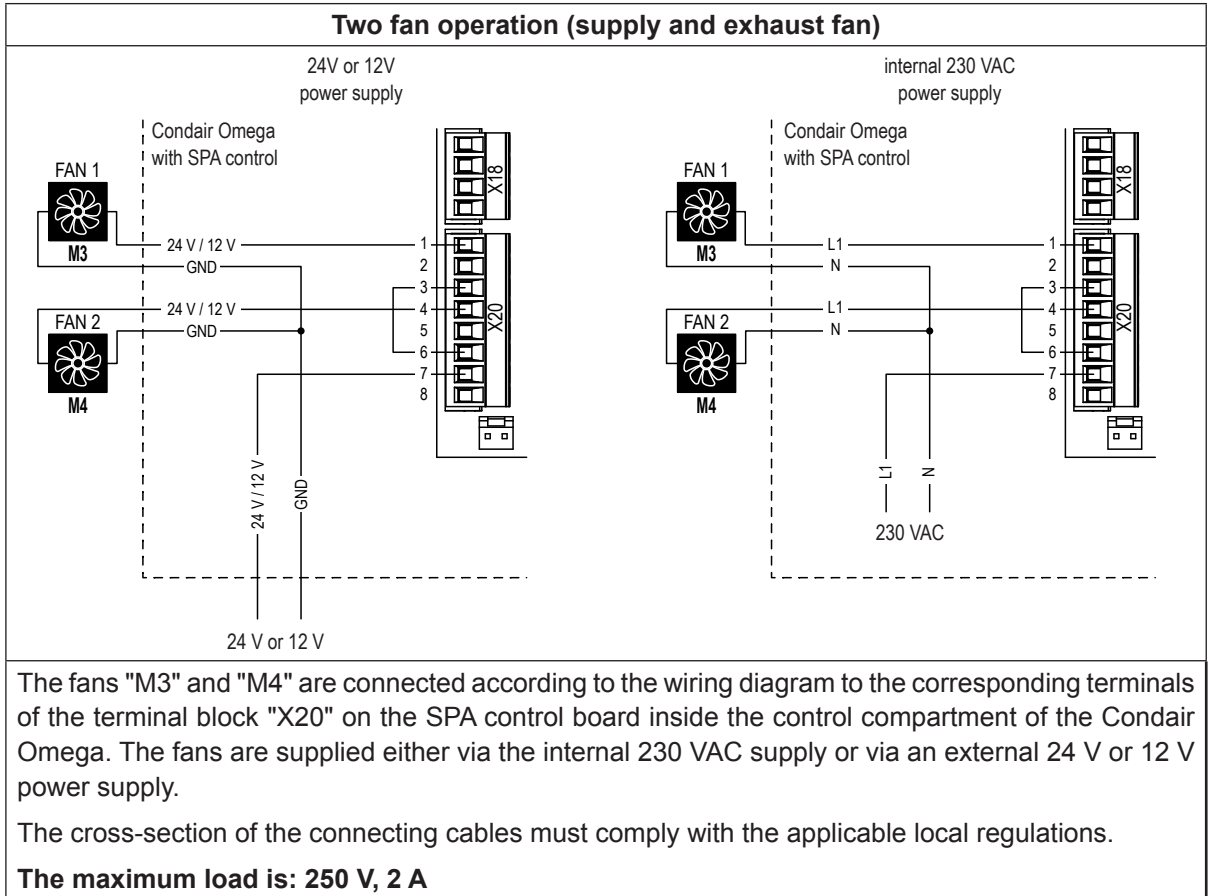

6.6.4.16 Connection of the optional bench heating for steam bath application

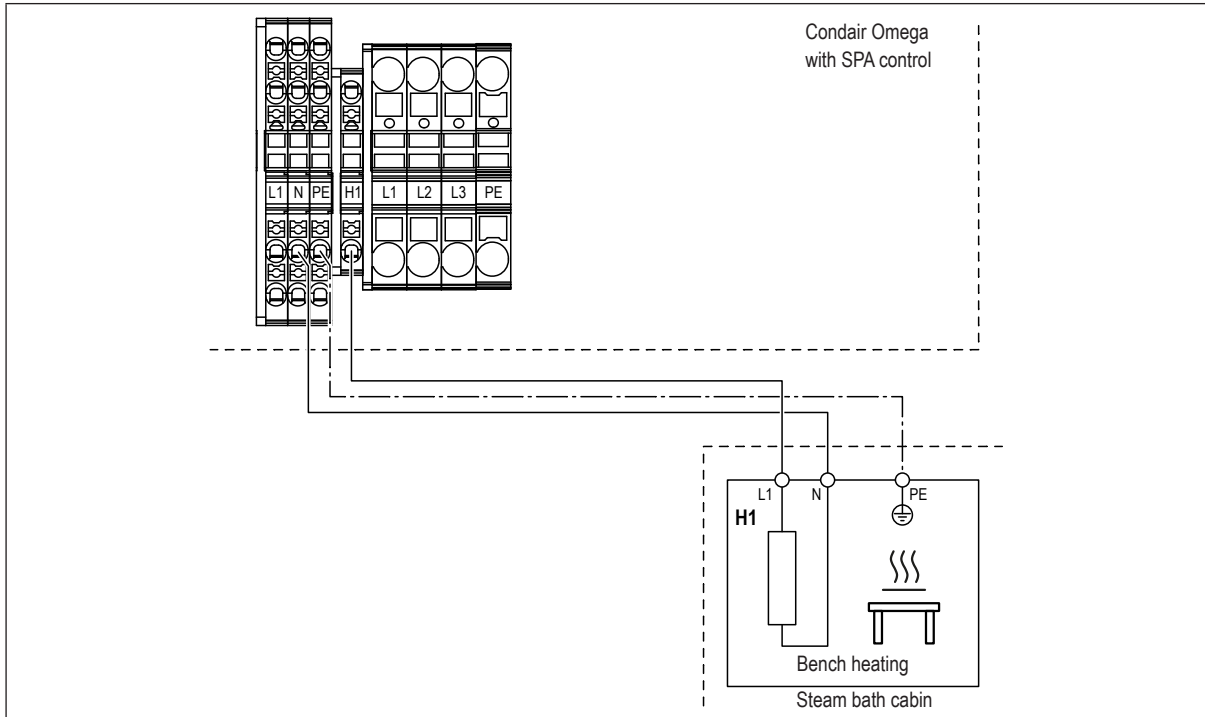

The bench heating "H1" ("L1", "N" and "PE") is connected according to the wiring diagram with a three-pole cable to the corresponding plug-in terminals inside the control compartment of the Condair Omega.

Connecting the cables to the plug-in terminals: Insert the stripped cable ends into the opening as far as they will go.

Important: Stranded cables must be provided with wire end ferrules for connection to the terminals.

The cross-section of the connection cable must comply with the applicable local regulations.

⚠ Caution: When wiring the bench heating, make sure that the neutral conductor terminal is used inside the control compartment of the Condair Omega.

⚠ Caution: Use only intrinsically safe bench heatings that have an overtemperature shut-down or have an overtemperature switch connected to the safety loop "SC".

The maximum load is: Bench heating 2 kW

6.6.4.17 Connection of the bench heating and the wall heating for caldarium and Rasul application

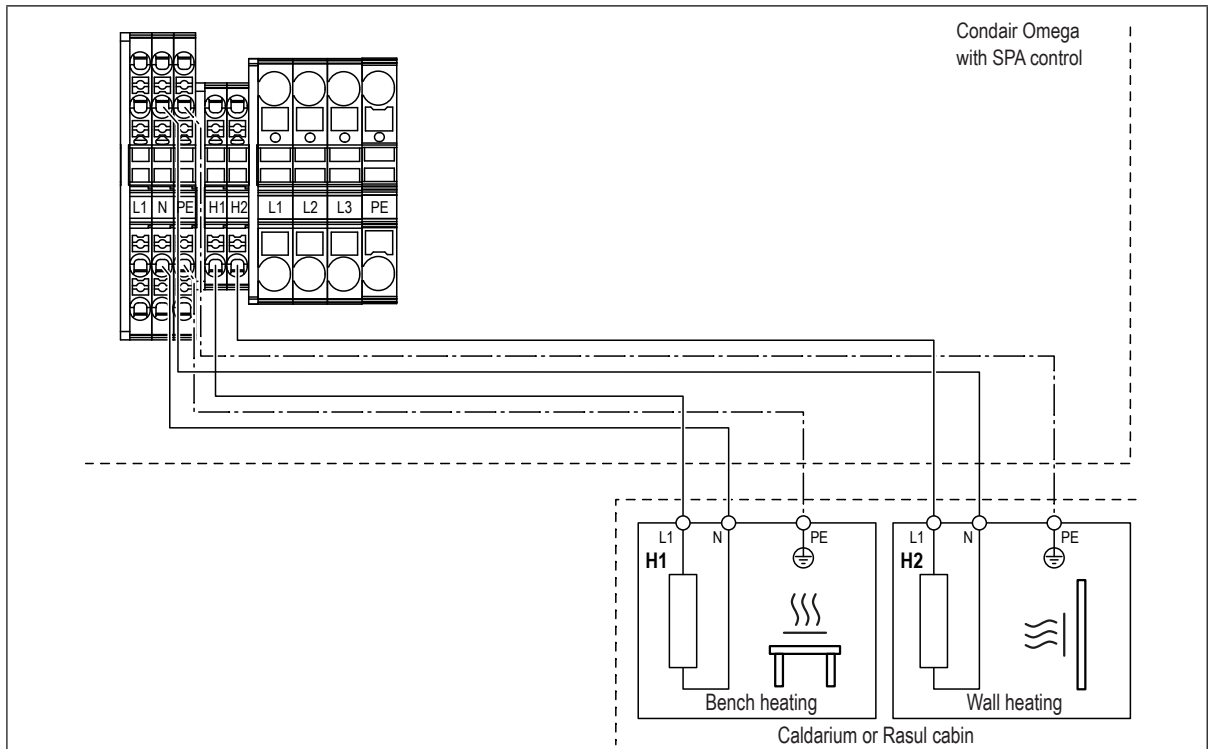

The bench heating "H1" ("L1", "N" and "PE") and the wall heating "H2" ("L1", "N" and "PE") are connected according to the wiring diagram with three-pole cables to the corresponding plug-in terminals inside the control compartment of the Condair Omega.

Connecting the cables to the plug-in terminals: Insert the stripped cable ends into the opening as far as they will go.

Important: Stranded cables must be provided with wire end ferrules for connection to the terminals.

The cross-section of the connecting cables must comply with the applicable local regulations.



Caution: When wiring the bench heating and the wall heating, make sure that the neutral conductor terminal is used inside the control compartment of the Condair Omega.



Caution: Use only intrinsically safe bench heaters and wall heaters that have an over-temperature shutdown or have an overtemperature switch connected to the safety loop "SC".

The maximum load is: bench heating 1 kW, wall heating 1 kW

6.6.4.18 Connection of the sauna heater for Bio sauna for single cabin application and for Fin sauna for dual cabin application

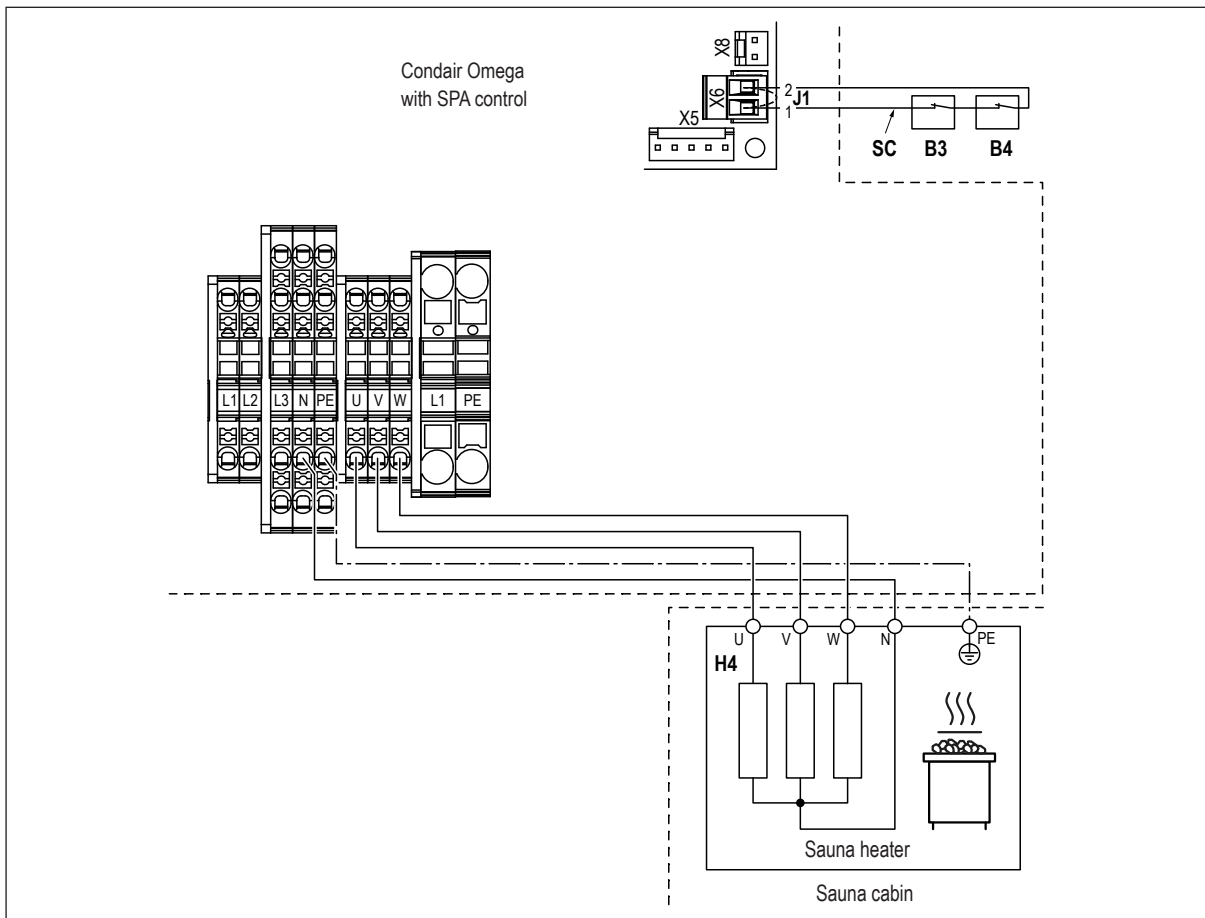

The sauna heater "H4" ("U", "V", "W", "N" and "PE") is connected according to the wiring diagram with a five-pin cable to the corresponding plug-in terminals inside the control compartment of the Condair Omega.

Note: For the connection of the sauna heater, please observe the instructions in the documentation supplied by the manufacturer.

Connecting the cables to the plug-in terminals: Insert the stripped cable ends into the opening as far as they will go.

Important: Stranded cables must be provided with wire end ferrules for connection to the terminals.

The cross-section of the connecting cable must comply with the applicable local regulations.



Caution Fire hazard: When wiring the heating of the sauna heater, make sure that the intended neutral conductor terminal is used inside the control compartment of the Condair Omega.



Caution: The sauna heater must be equipped with a certified safety system (e.g. a protective cover) to avoid switching the sauna heater on in an unsafe condition (e.g. towel on heater). This security device ("B4") must be connected to the security loop "SC".

The maximum load is: sauna heater 9 kW

6.6.4.19 Connection of the relays "Rel 8" and "Rel 9"

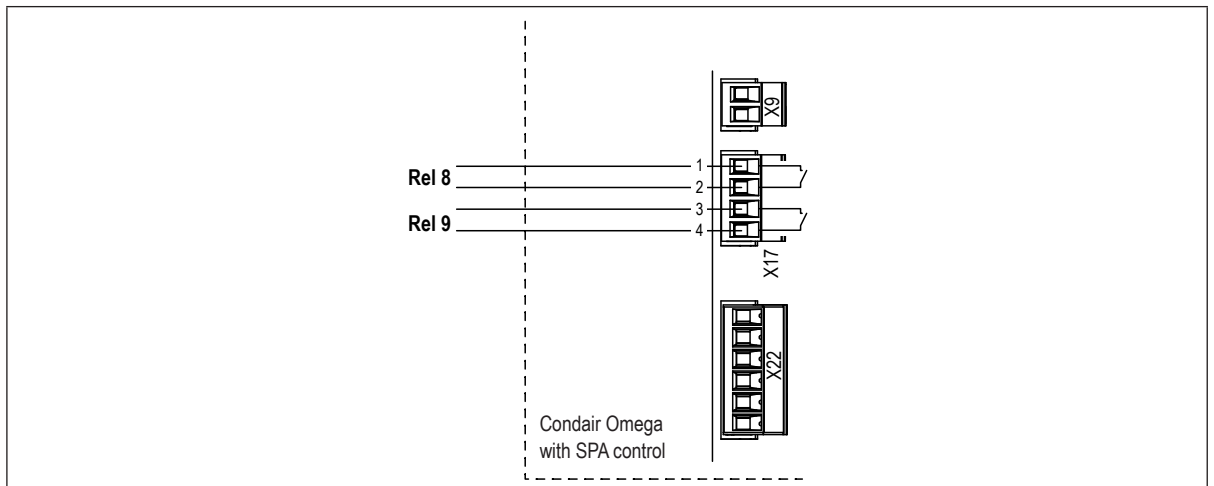

The potential-free relay contacts "Rel 8" and "Rel 9" are used to control components (e.g. loudspeakers, additional light) in the SPA cabin. These components are connected according to the wiring diagram to terminals "1" and "2" ("Rel 8") or "3" and "4" ("Rel 9") of terminal block "X17" inside the control box of the Condair Omega.

The cross-section of the connecting cables must comply with the applicable local regulations.

The maximum load is: 250 V, 10 A

Notes:

- For the Caldarium and Rasul applications, the relay contacts "Rel 8" and "Rel 9" are used to control the bench heating and wall heating.
- For the steam bath application, the relay contact "Rel 8" is used to control the optional bench heating.
- For dual cabin application for small cabins, the relay contact "Rel 8" is used to control the color light ("E3") of the sauna cabin.
- For steam bath, Caldarium, Rasul and Bio sauna applications, one of the relay contacts "Rel 8" or "Rel 9" can be used to control a display indicating an active steam blast. However, it may be necessary to forego another function for this.
- The function of the relay contacts is programmable via the SPA control software.

6.6.4.20 Connection of the fault output "Err. Out"

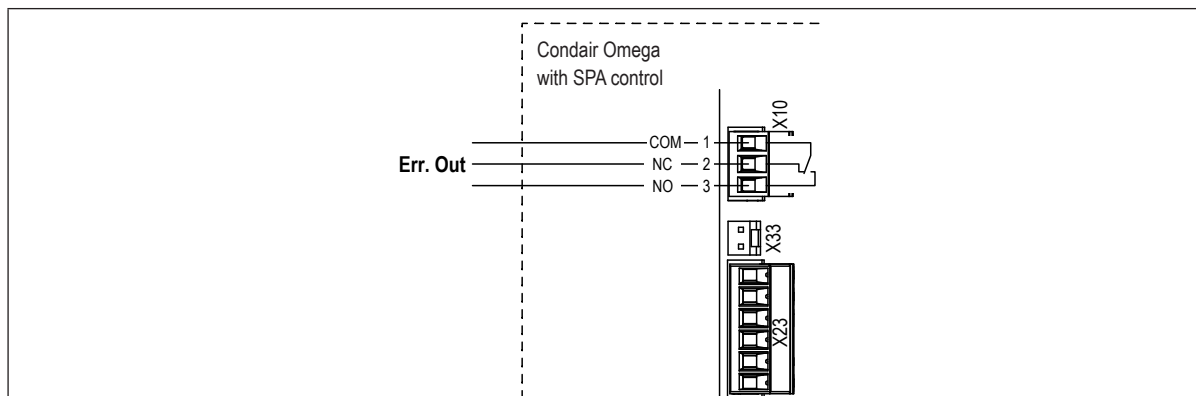

The potential-free "Err. Out" contact can be used for error signaling to external devices. In normal operation (no errors present) the contact between 1-3 is closed. In the event of a fault (a warning is not considered an error), the contact between 1-2 is closed.

Note: When the device is switched off, the contact is in the idle position between 1-2.

The cross-section of the connecting cables must comply with the applicable local regulations.

The maximum contact load is: 250 V, 3 A

6.6.4.21 Connection of external safety chain

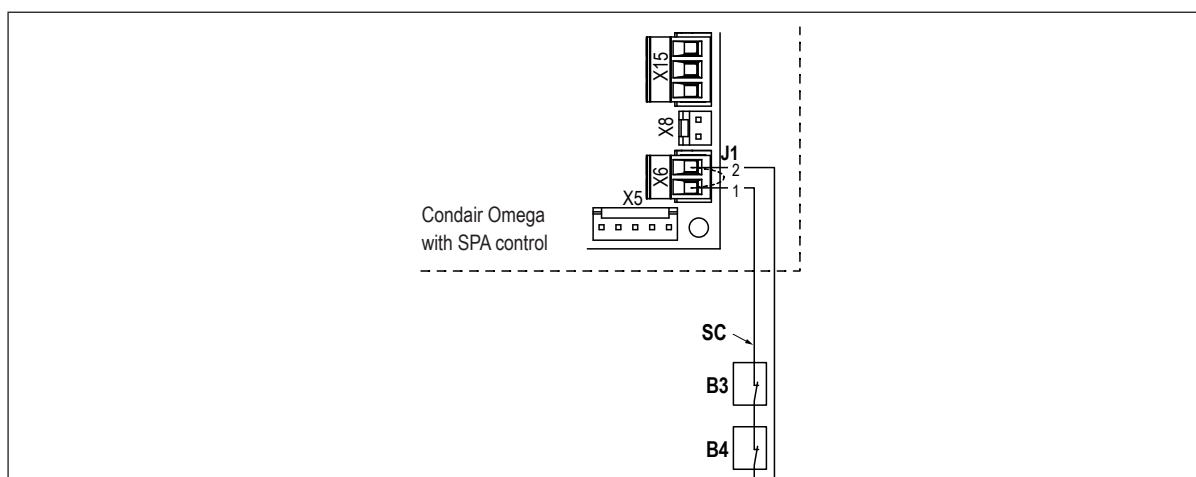

The potential-free contacts of external monitoring devices "B3" (e.g. emergency stop) and "B4" (safety device sauna heater) of the external safety chain "SC" are connected according to the wiring diagram in series (if more than one monitoring device is connected) to the terminals of terminal block "X6" to the SPA control board inside the control compartment of the Condair Omega.

Note: If no monitoring devices are connected to the terminals of terminal block "X6", a wire jumper "J1" must be connected to the terminals.

The safety chain is operated with 24 VDC. In the event of a fault, the safety contact is opened, thus interrupting the safety chain. Use only approved 24 VDC safety devices.



CAUTION! Do not apply any external voltage via the contacts of the external monitoring devices "B3" and "B4" to terminal "X6"!

6.6.4.22 Connecting the external SPA display(s) (accessory)

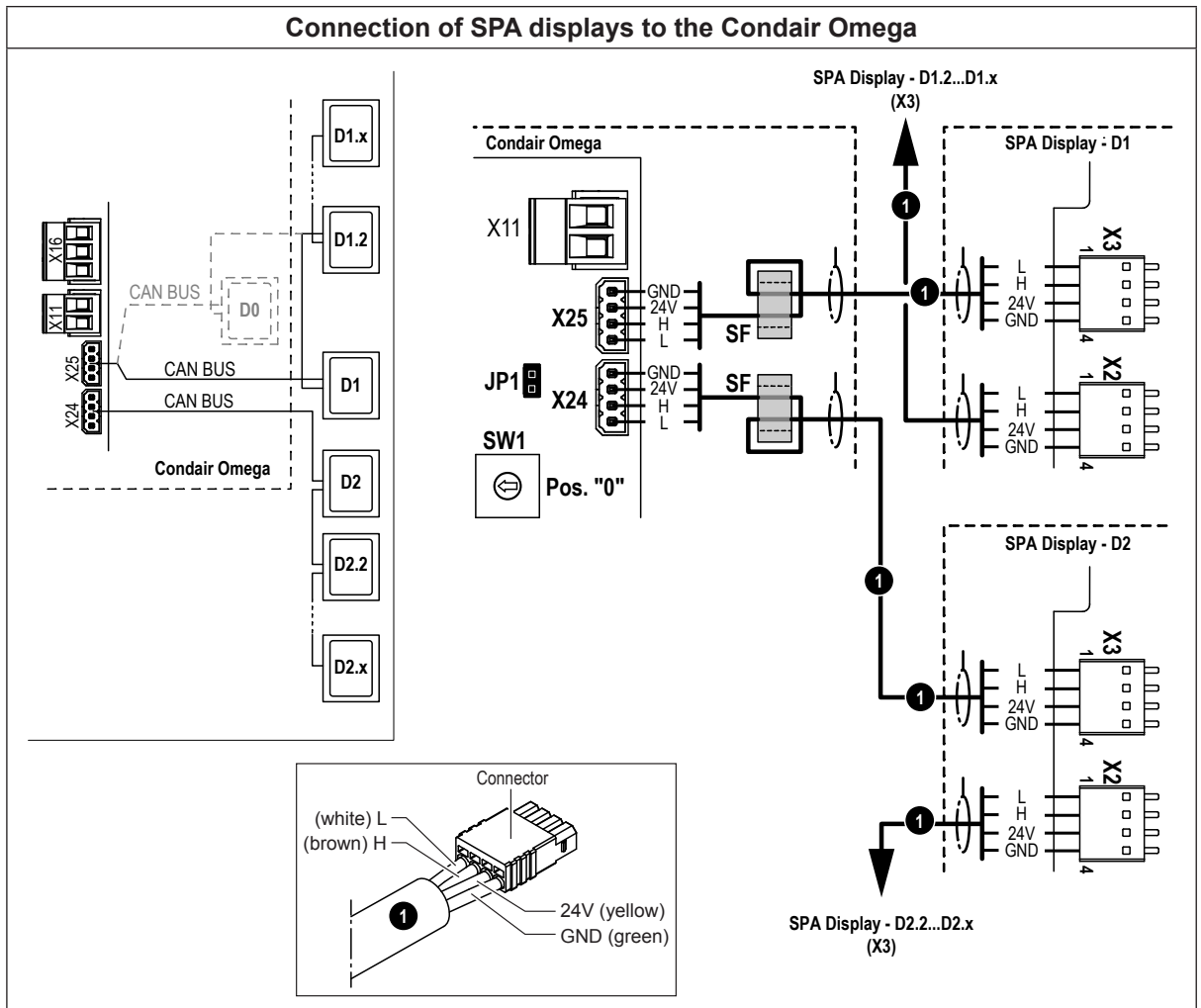

The external SPA displays "D1" and "D2" available as accessories are connected according to the wiring diagram to the CAN BUS connectors "X25" or "X24" via a CAN BUS cable (see above). Both SPA displays "D1" (or "D0") and "D2" can be connected to additional SPA displays (total 8 SPA displays) via the CAN BUS. Detailed instructions can be found in the separate manual supplied with the external SPA displays.

Note: With the Condair Omega with integrated SPA display "X0" (option) the display is connected ex works to the CAN BUS connection "X25".

Important: If displays are connected to both CAN BUS ports ("X25" and "X24") of the SPA control board of the Condair Omega, the jumper "JP1" (terminating resistor) on the SPA control board must be removed (see wiring diagrams in [chapter 6.6.3](#)).

Connection of the SPA displays to the Condair Omega in combination with the Condair SPA Control Box

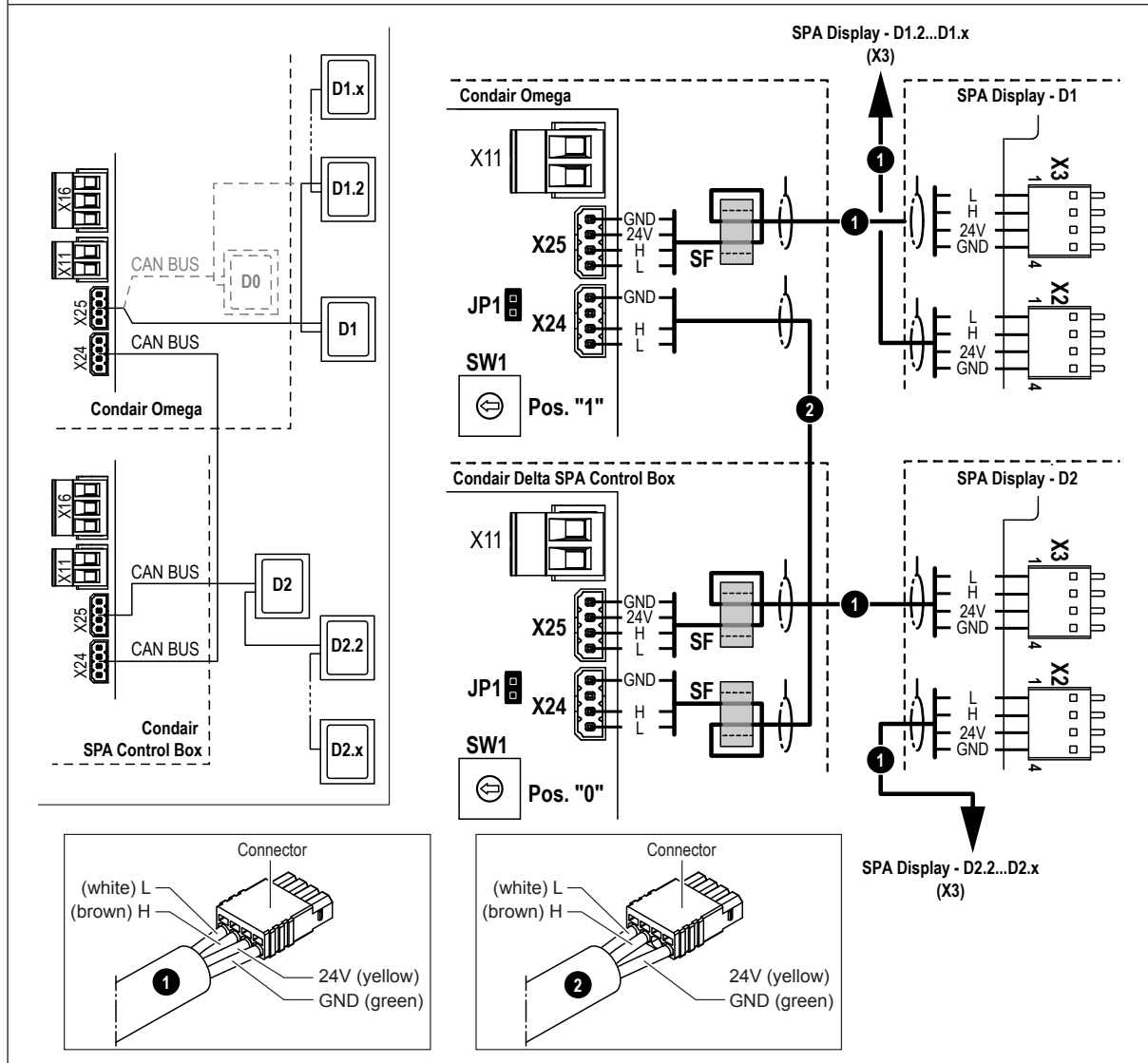

If a Condair Omega is used in combination with a Condair Delta SPA Control Box, the CAN BUS connector "X24" of the Condair Delta SPA Control Box must be connected via a CAN BUS cable without "24 V" conductor (cable No. 2) to the CAN BUS connector "X24" inside the control compartment of the Condair Omega.

The external SPA displays "D1" and "D2", which are available as accessories, are connected according to the connection diagram (see above) via a CAN BUS cable (cable no. 1) to the CAN BUS connector "X25" in the Condair Delta SPA Control Box or Condair Omega, respectively.

To both SPA displays "D1" (or "D0") and "D2" additional SPA displays (total 8 SPA displays) can be connected via the CAN BUS. Detailed instructions can be found in the separate manual supplied with the external SPA displays.

Note: With the Condair Omega with integrated SPA display "X0" (option) the display is connected ex works to the CAN BUS connection "X25".

Important: If displays are connected to both CAN BUS ports ("X25" and "X24") of the SPA control board of the Condair Omega or the Condair Delta SPA Control Box, the jumper "JP1" (terminating resistor) on the SPA control board must be removed (see wiring diagrams in [chapter 6.6.3](#)).

Important: If a Condair Delta SPA Control Box is used in combination with a Condair Omega, the rotary switch "SW1" on the SPA control board of the Condair Delta SPA Control Box must be set to position "0" and the one on the SPA control board of the Condair Omega to position "1".

Connecting the CAN BUS cable

1. Lead the CAN BUS cable(s) (4-wire, shielded, 0.34 mm² per strand) via cable glands from below into the control compartment of the Condair Omega or into the Condair Delta SPA Control Box.
2. Guide the CAN BUS cable(s) in a loop through the ferrite ring(s) as shown in [Fig. 28](#).
3. Cut the CAN BUS cable(s) to length. Prepare the cable end(s) as shown in [Fig. 26](#) (SPA Display connection) or [Fig. 27](#) (connection cable Condair Delta SPA Control Box to Condair Omega), then connect the prepared cable ends to the the CAN BUS connectors.

Important: On the CAN BUS cable between the Condair Delta SPA Control Box ("X24") and the Condair Omega ("X24") the 24V conductor must be cut off not be connected to the CAN BUS connector, otherwise the system may not function properly.

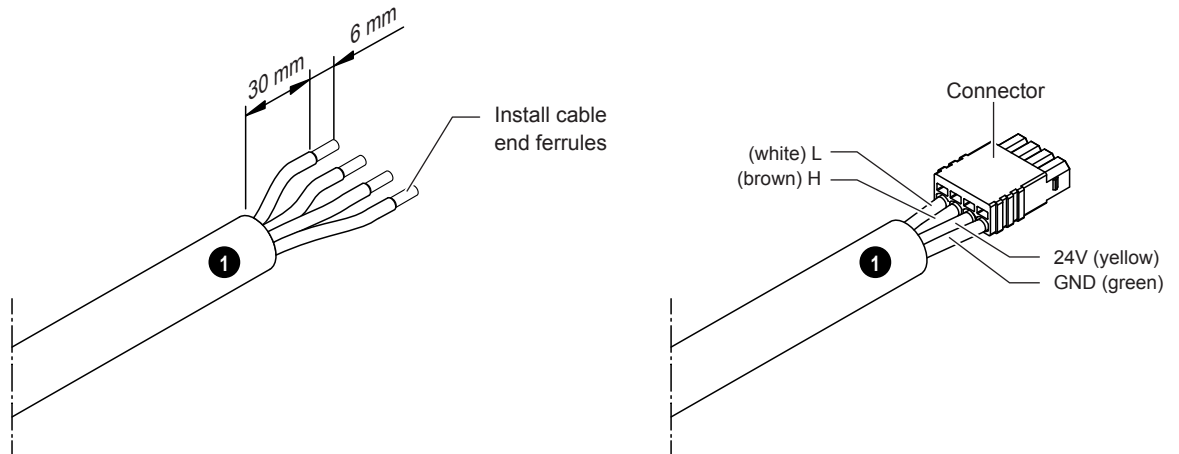

Fig. 26: Prepare CAN BUS cable for SPA Display connection

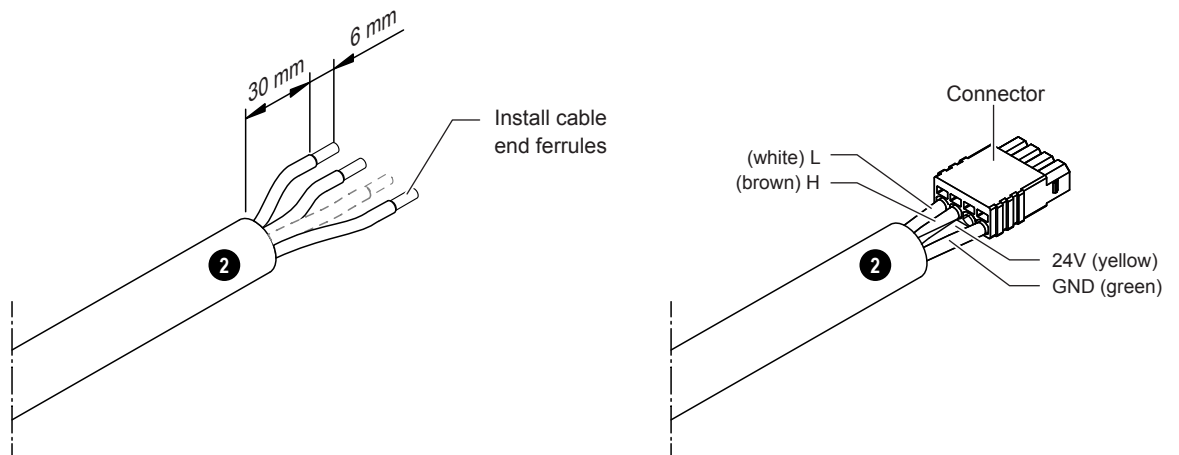

Fig. 27: Prepare CAN BUS cable for the connection between Condair Delta SPA Control Box and Condair Omega

4. Connect the prepared CAN BUS cable(s) to the corresponding connectors "X25" and/or "X24" on the control board of the Condair Omega according to the applicable diagram in this chapter.

- Free the shielding of the CAN BUS cable(s) by removing the insulation at the appropriate position. Then, pinch the freed shielding of the CAN BUS cable(s) into the clamp holder(s) on the right side of the Condair Delta SPA Control Box or in the bottom of the Condair Omega housing, respectively.

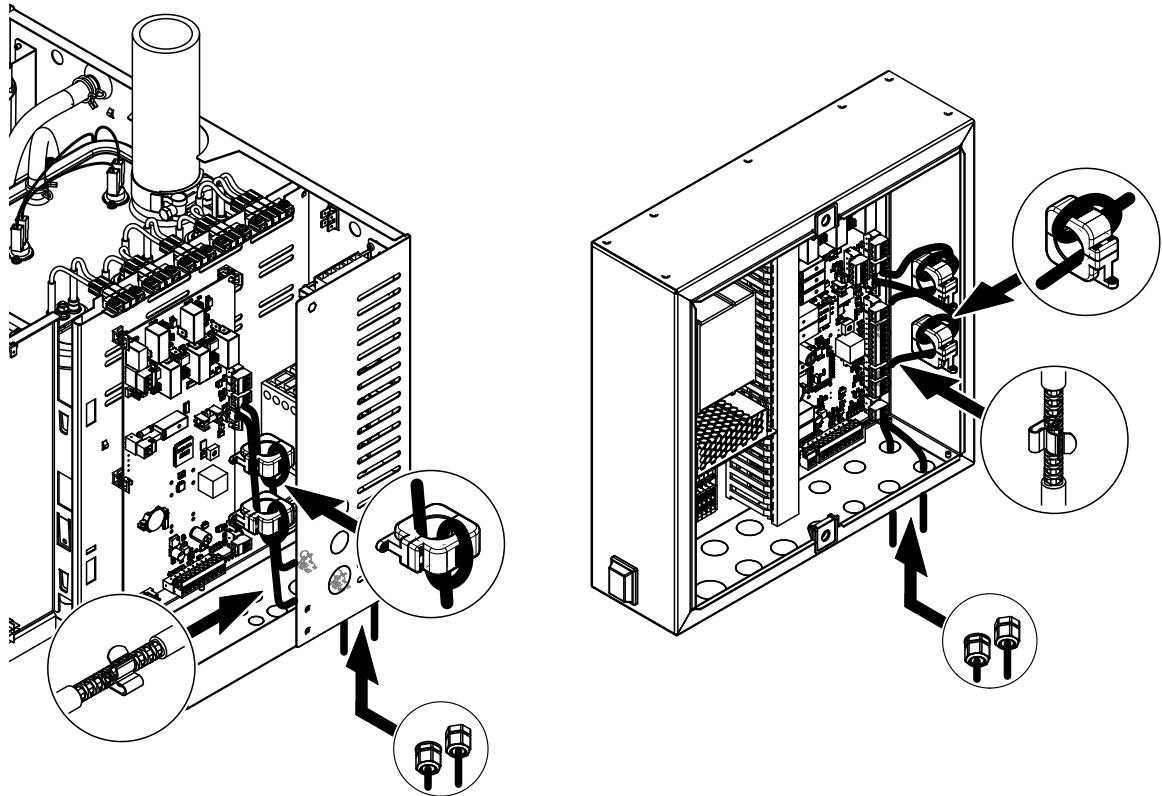
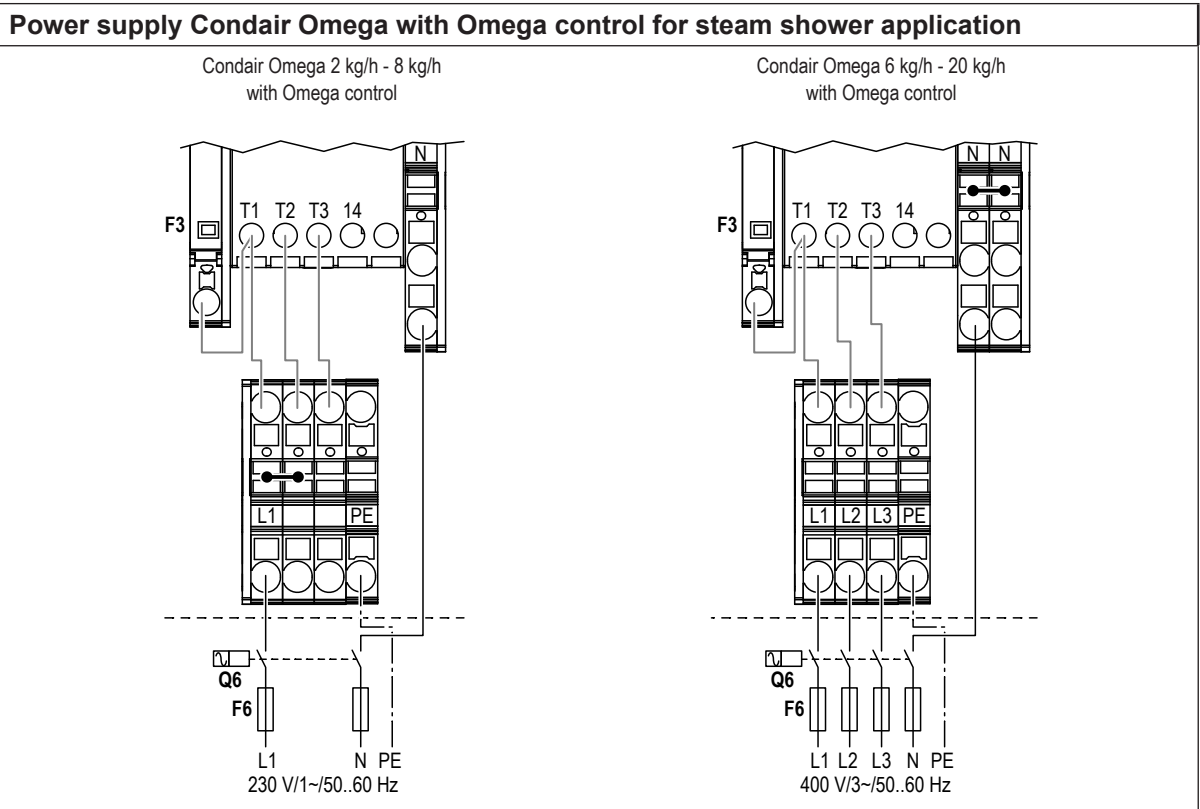

Fig. 28: Leading the cable through the ferrite ring and secure the cable shield in the clamp holder

6.6.4.23 Power supplies



The 230 V/1~/50..60Hz power supply ("L1", "N" and "PE") for the Condair Omega 2 - 8 kg/h and the 400 V/3~/50..60Hz power supply ("L1", "L2", "L3", "N" and "PE") for the Condair Omega 6 - 20 kg/h are connected according to the wiring diagram to the corresponding plug-in terminals inside the control compartment of the Condair Omega.

Connecting the cables to the plug-in terminals: Insert the stripped cable ends into the opening as far as they will go.

Important: Stranded cables must be provided with wire end ferrules for connection to the terminals.

The installation of the fuses "F6" and the electrical isolator "Q6" (all pole disconnecting device with a minimum contact clearance of 3 mm, supplied by others) in the mains supply line is mandatory. The value of the fuses "F6" and the cross-section of the supply line conductors can be found in the table below.

	230 V/1~/50...60 Hz		400V/3~/50...60 Hz	
	F6	Conductor cross section	F6	Conductor cross section
2 kg/h	10 A, fast acting	1.5 mm ²	–	–
4 kg/h	16 A, fast acting	2.5 mm ²	–	–
6 kg/h	25 A, fast acting	6 mm ²	16 A, fast acting	2.5 mm ²
8 kg/h	32 A, fast acting	6 mm ²	16 A, fast acting	2.5 mm ²
12 kg/h	–	–	16 A, fast acting	2.5 mm ²
16 – 20 kg/h	–	–	32 A, fast acting	6 mm ²

The electrical isolator must be mounted in direct proximity of the Condair Omega (max. distance 1 m) and must be easily accessible.

CAUTION! Make sure that the local mains voltage corresponds to the voltage values of 230 V/1~/50..60Hz and 400 V/3~/50..60Hz stated on the wiring diagram. Otherwise, do not connect the Condair Omega.

The cable cross-section of the mains cable must comply with the applicable local regulations.

Power supply Condair Omega with SPA Control for steam bath application

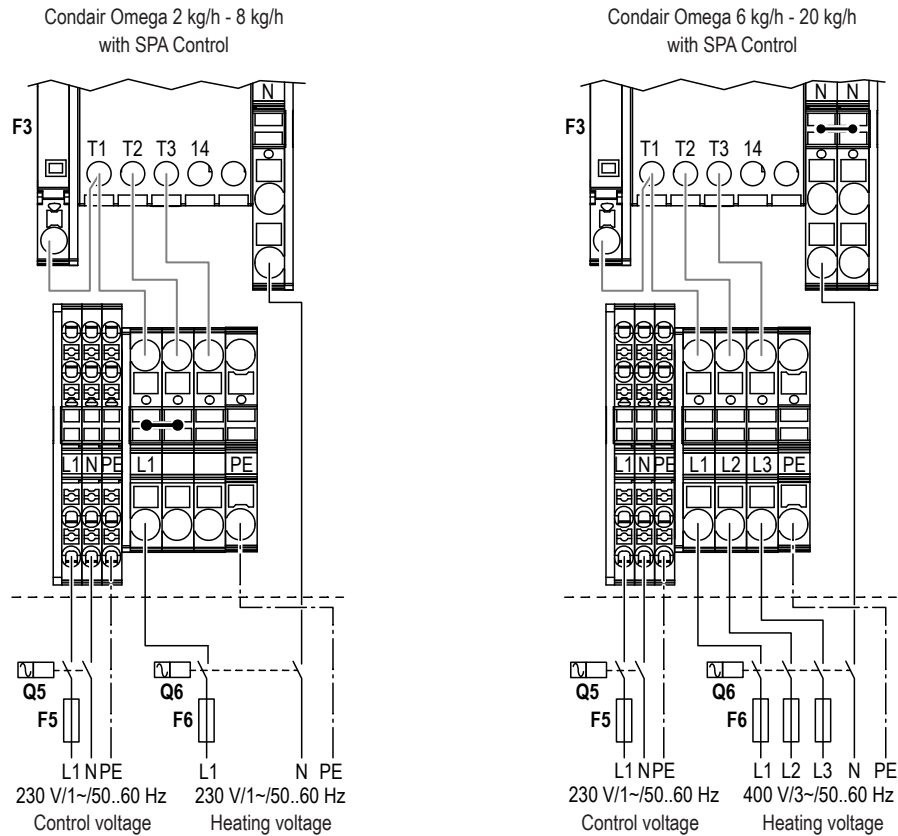

The 230 V/1~/50..60Hz power supply ("L1", "N" and "PE") for the control of the accessories (control voltage) and the 400 V/3~/50..60Hz power supply ("L1", "L2", "L3", "N" and "PE") or 230 V/1~/50..60Hz power supply ("L1", "N" and "PE"), respectively for the steam generation (heating voltage) are connected according to the wiring diagram to the corresponding plug-in terminals inside the control compartment of the Condair Omega.

Connecting the cables to the plug-in terminals: Insert the stripped cable ends into the opening as far as they will go.

Important: Stranded cables must be provided with wire end ferrules for connection to the terminals.

The installation of the fuse "F5" (without bench heating: 10A, fast acting, with bench heating: 16A, fast acting), the fuses "F6" and the electrical isolators "Q5" and "Q6" (all pole disconnecting device with a minimum contact clearance of 3 mm, supplied by others) in the mains supply lines is mandatory. The value of the fuses "F6" and the cross-section of the supply line conductors can be found in the table below.

	230 V/1~/50..60 Hz		400V/3~/50..60 Hz	
	F6	Conductor cross section	F6	Conductor cross section
2 kg/h	10 A, fast acting	1.5 mm ²	–	–
4 kg/h	16 A, fast acting	2.5 mm ²	–	–
6 kg/h	25 A, fast acting	6 mm ²	16 A, fast acting	2.5 mm ²
8 kg/h	32 A, fast acting	6 mm ²	16 A, fast acting	2.5 mm ²
12 kg/h	–	–	16 A, fast acting	2.5 mm ²
16 – 20 kg/h	–	–	32 A, fast acting	6 mm ²

The electrical isolators must be mounted in direct proximity of the Condair Omega (max. distance 1 m) and must be easily accessible.

CAUTION! Make sure that the local mains voltage corresponds to the voltage values of 230 V/1~/50..60Hz and 400 V/3~/50..60Hz stated on the wiring diagram. Otherwise, do not connect the Condair Omega.

The cable cross-section of the mains cable must comply with the applicable local regulations.

Power supply Condair Omega with SPA Control for Caldarium and Rasul application

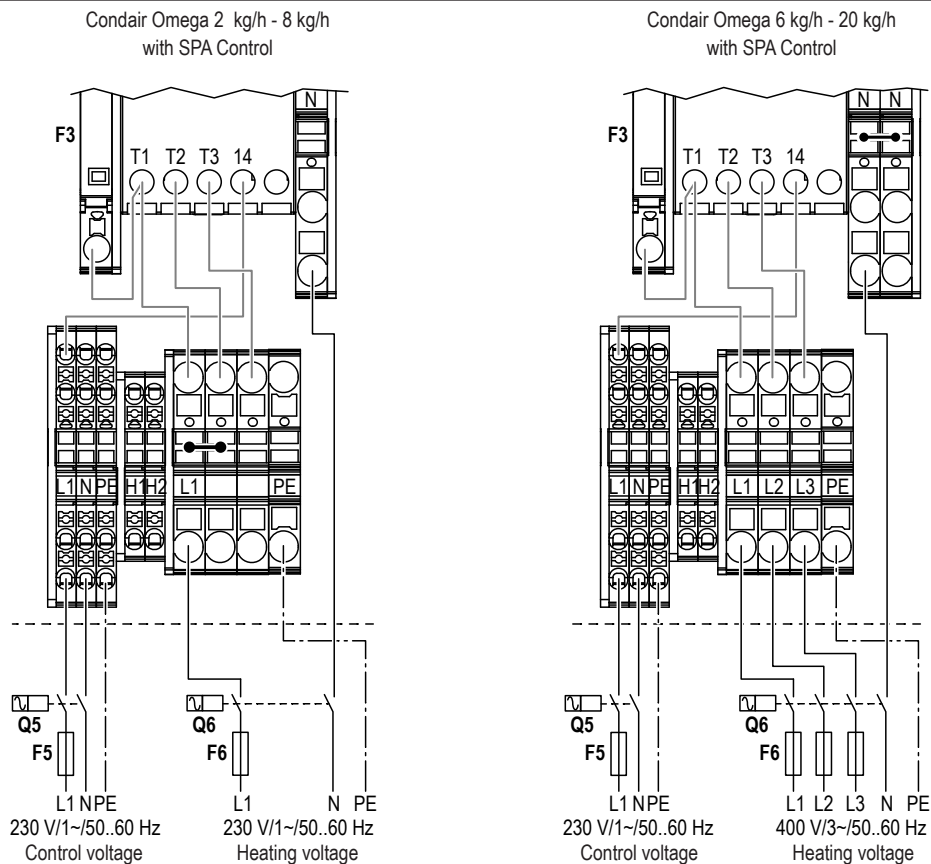

The 230 V/1~/50..60Hz power supply ("L1", "N" and "PE") for the control of the accessories (control voltage) and the 400 V/3~/50..60Hz power supply ("L1", "L2", "L3", "N" and "PE") or 230 V/1~/50..60Hz power supply ("L1", "N" and "PE"), respectively for the steam generation (heating voltage) are connected according to the wiring diagram to the corresponding plug-in terminals inside the control compartment of the Condair Omega.

Connecting the cables to the plug-in terminals: Insert the stripped cable ends into the opening as far as they will go.

Important: Stranded cables must be provided with wire end ferrules for connection to the terminals.

The installation of the fuse "F5", the fuses "F6" and the electrical isolators "Q5" and "Q6" (all pole disconnecting device with a minimum contact clearance of 3 mm, supplied by others) in the mains supply lines is mandatory. The value of the fuses "F6" and the cross-section of the supply line conductors can be found in the table below.

	230 V/1~/50..60 Hz		400V/3~/50..60 Hz	
	F6	Conductor cross section	F6	Conductor cross section
2 kg/h	10 A, fast acting	1.5 mm ²	–	–
4 kg/h	16 A, fast acting	2.5 mm ²	–	–
6 kg/h	25 A, fast acting	6 mm ²	16 A, fast acting	2.5 mm ²
8 kg/h	32 A, fast acting	6 mm ²	16 A, fast acting	2.5 mm ²
12 kg/h	–	–	16 A, fast acting	2.5 mm ²
16 – 20 kg/h	–	–	32 A, fast acting	6 mm ²

The electrical isolators must be mounted in direct proximity of the Condair Omega (max. distance 1 m) and must be easily accessible.



CAUTION! Make sure that the local mains voltage corresponds to the voltage values of 230 V/1~/50..60Hz and 400 V/3~/50..60Hz stated on the wiring diagram. Otherwise, do not connect the Condair Omega.

The cable cross-section of the mains cable must comply with the applicable local regulations.

Power supply Condair Omega 2 kg/h with SPA Control for Bio sauna application

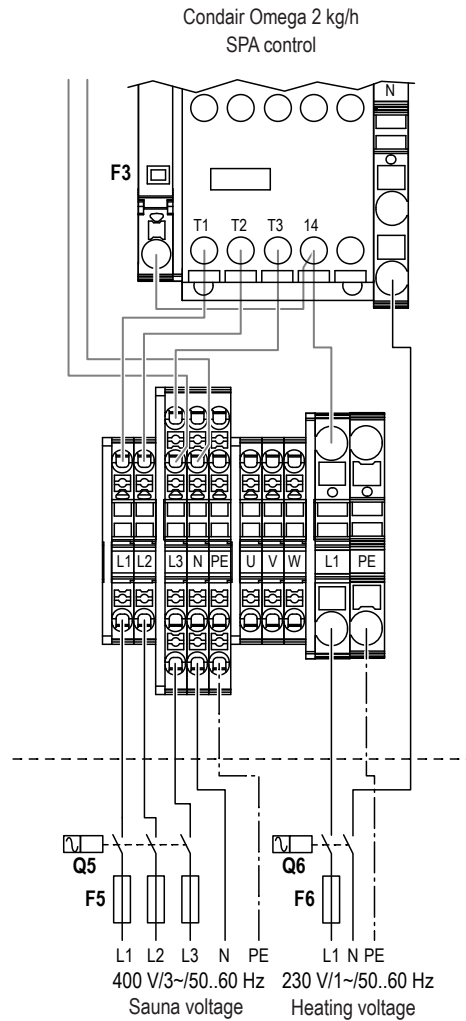

The 230 V/1~/50..60Hz power supply ("L1", "N" and "PE") for the steam generation (heating voltage) and the 400 V/3~/50..60Hz power supply ("L1", "L2", "L3", "N" and "PE") for the sauna heater and the control of the accessories are connected according to the wiring diagram to the corresponding plug-in terminals inside the control compartment of the Condair Omega.

Connecting the cables to the plug-in terminals: Insert the stripped cable ends into the opening as far as they will go.

Important: Stranded cables must be provided with wire end ferrules for connection to the terminals.

The installation of the **fuses "F5" (16 A, fast acting) and "F6" (10 A, fast acting)** and the electrical isolators **"Q5"** and **"Q6"** (all pole disconnecting device with a minimum contact clearance of 3 mm, supplied by others) in the mains supply lines is mandatory.

The electrical isolators must be mounted in direct proximity of the Condair Omega (max. distance 1 m) and must be easily accessible.

CAUTION! Make sure that the local mains voltage corresponds to the voltage values of 230 V/1~/50..60Hz and 400 V/3~/50..60Hz stated on the wiring diagram. Otherwise, do not connect the Condair Omega.

The cable cross-section of the mains cable must comply with the applicable local regulations.

Power supply Condair Omega 8kg/h with SPA Control for dual cabin application for small cabins (Fin sauna / Steam bath)

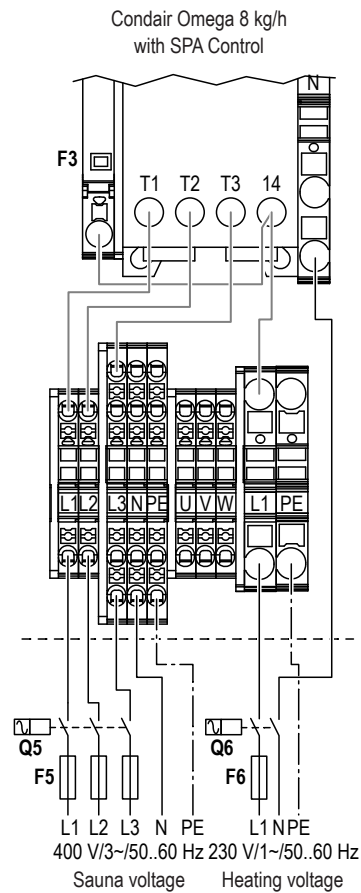

The 230 V/1~/50..60Hz power supply ("L1", "N" and "PE") for the steam generation (heating voltage) and the 400 V/3~/50..60Hz power supply ("L1", "L2", "L3", "N" and "PE") for the sauna heater and for the control of the accessories are connected according to the wiring diagram to the corresponding plug-in terminals inside the control compartment of the Condair Omega.

Connecting the cables to the plug-in terminals: Insert the stripped cable ends into the opening as far as they will go.

Important: Stranded cables must be provided with wire end ferrules for connection to the terminals.

The installation of the fuses "F5" (16 A, fast acting), the fuses "F6" (32 A, fast acting) and the electrical isolators "Q5" and "Q6" (all pole disconnecting devices with a minimum contact clearance of 3 mm, supplied by others) in the mains supply line is mandatory.

The electrical isolators must be mounted in direct proximity of the Condair Omega (max. distance 1 m) and must be easily accessible.



CAUTION! Make sure that the local mains voltage corresponds to the voltage values of 230 V/1~/50..60Hz and 400 V/3~/50..60Hz stated on the wiring diagram. Otherwise, do not connect the Condair Omega.

The cable cross-section of the mains cable must comply with the applicable local regulations.

Power supply Condair Omega 8kg/h with SPA Control for dual cabin application for small cabins (Fin sauna / Steam bath), with external power supply of the sauna heater

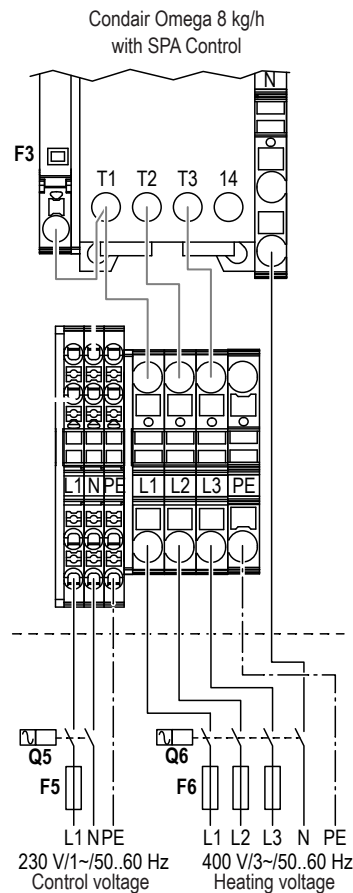

The 230 V/1~/50..60Hz power supply ("L1", "N" and "PE") for the control of the accessories (control voltage) and the 400 V/3~/50..60Hz power supply ("L1", "L2", "L3", "N" and "PE") for the steam generation (heating voltage) are connected according to the wiring diagram to the corresponding plug-in terminals inside the control compartment of the Condair Omega.

Connecting the cables to the plug-in terminals: Insert the stripped cable ends into the opening as far as they will go.

Important: Stranded cables must be provided with wire end ferrules for connection to the terminals.

The installation of the fuses "F5" (10 A, fast acting), the fuses "F6" (16 A, fast acting) and the electrical isolators "Q5" and "Q6" (all pole disconnecting devices with a minimum contact clearance of 3 mm, supplied by others) in the mains supply line is mandatory.

The electrical isolators must be mounted in direct proximity of the Condair Omega (max. distance 1 m) and must be easily accessible.



CAUTION! Make sure that the local mains voltage corresponds to the voltage values of 230 V/1~/50..60Hz and 40 ..60Hz stated on the wiring diagram. Otherwise, do not connect the Condair Omega.

The cable cross-section of the mains cable must comply with the applicable local regulations.

6.6.5 Performance data / Fuses "F5" power supply

Condair Omega	230V/1~/50...60 Hz						400V/3~/50...60 Hz					
	Max. steam capacity in kg/h	P _N max. in kW	I _N max. in A	Cable cross section A _L min. in mm ²	Fuses "F5" in A, fast acting (gR)	Max. steam capacity in kg/h	P _N max. in kW	I _N max. in A	Cable cross section A _L min. in mm ²	Fuses "F5" in A, fast acting (gR)		
S	2	2.0	2.0	8.7	1.5	10	—	—	—	—	—	
	4	4.0	3.5	15.3	2.5	16	—	—	—	—	—	
	6	6.0	5.0	21.8	6.0	25	6.0	5.0	12.0	2.5	16	
	8	8.0	6.5	28.3	6.0	32	8.0	6.5	15.3	2.5	16	
	8	8.0	6.5	28.3	6.0	32	—	—	—	—	—	
M	12	—	—	—	—	—	12.0	9.5	15.3	2.5	16	
	16	—	—	—	—	—	16.0	12.5	26.1	6.0	32	
	20	—	—	—	—	—	20.0	15.5	26.1	6.0	32	

Note: The values marked in gray are only valid for the Condair Omega 8 with SPA Control for dual cabin application (Fin sauna/ steam bath) for small cabins. In this variant, the heating elements for the steam generation are supplied with 230V/1~/50...60 Hz.

6.6.6 Maximum power consumption accessories for Condair Omega with SPA Control

Application	Accessories										
	Light		Ventilation		Fragrance		Additional Relay		Shower	Heating	
	Light 1	Light 2	Fan 1	Fan 2	Fragrance 1 (Pump 1)	Fragrance 2 (Pump 2)	Music, ... (Rel 8)	Music, ... (Rel 9)	Shower (Pump 2)	Bench heating (Rel 8)	Wall heating (Rel 9)
Steam bath	Max. 1 kW								-	max. 2 kW	-
Caldarium	Max. 1 kW								-	max. 1 kW	max. 1 kW
Rasul	Max. 1 kW								-	max. 1 kW	max. 1 kW
Bio sauna	Max. 0.5 kW								-	-	-
Dual cabin (small)	Max. 0.5 kW								-	-	-
Dual cabin (medium large)	Depending on the single cabin used (see above)										
	Depending on the single cabin used (see above)										

6.6.7 Connection data accessories

Connection data accessories

Application	Hardware variant	Control voltage Accessories	Control power Accessories max. in kW	Cable cross section supply line in mm ²	Fuse F5 fast acting in A
Steam bath	SPA Control with standard equipment	230 V/1~/50...60 Hz	1	1.5	10
Steam bath with bench heating	SPA Control with equipment for bench heating		3	2.5	16
Caldarium	SPA Control with equipment for bench and wall heating		3	2.5	16
Rasul	SPA Control with equipment for bench and wall heating		3	2.5	16
Bio sauna	SPA Control with equipment for Fin sauna	In this variant the accessories are supplied via the sauna voltage			
Dual cabin (small)	SPA Control with equipment for Fin sauna	In this variant the accessories are supplied via the sauna voltage			
	SPA Control with standard equipment	230 V/1~/50...60 Hz	1	1,5	10

Connection data sauna (Dual cabin application for small cabins)

Application	Hardware variant	Sauna voltage	Max. power consumption sauna in kW	Cable cross section supply line in mm ²	Absicherung F6 fast acting in A
Bio sauna	SPA Control with equipment for Fin sauna	400 V/3~/50...60 Hz	9,5 kW	2,5	16
Dual cabin (small)	SPA Control with equipment for Fin sauna	400 V/3~/50...60 Hz	9,5 kW	2,5	16

Note: In dual cabin application with the variant SPA Control with equipment for Fin sauna the accessories are supplied via the sauna voltage.

6.6.8 Inspecting the electrical installation

Check the following points:

- Does/do the supply voltage(s) for the respective SPA application meet the specifications in the corresponding wiring diagram and is/are the power supply/supplies and is/are the power supply/supplies connected in accordance with the wiring diagram?
- Is/are the power supply/supplies correctly fused (fuse values "F5" and "F6" see wiring diagrams in [chapter 6.6.4.23](#))?
- Is/are the electrical isolator(s) "Q5" or "Q5" and "Q6", respectively installed in the power supply line?
- Are all components correctly connected according to the wiring diagram?
- Are all connecting cables fastened?
- Are the connecting cables free of tension (passed through cable glands?)
- Have splash-proof cable glands been used?
- Does the electric installation meet the applicable local regulations for electric installations?
- Is a approved safety device (e.g. protective cover) attached to the sauna heater and is the corresponding safety device connected in series via the safety loop "SC"?
- Have intrinsically safe bench and wall heatings been used or has a corresponding overtemperature switch been integrated in series into the safety loop "SC"?
- Have the maximum capacities for the cabin volume used not been exceeded?
- Have the maximum power consumptions for the accessories been complied with (see [chapter 6.6.7](#))?
- Is the housing cover relocated and locked with the screw?

7 Appendix

7.1 Unit dimensions

7.1.1 Unit dimensions unit "Small" (Condair Omega 2...8)

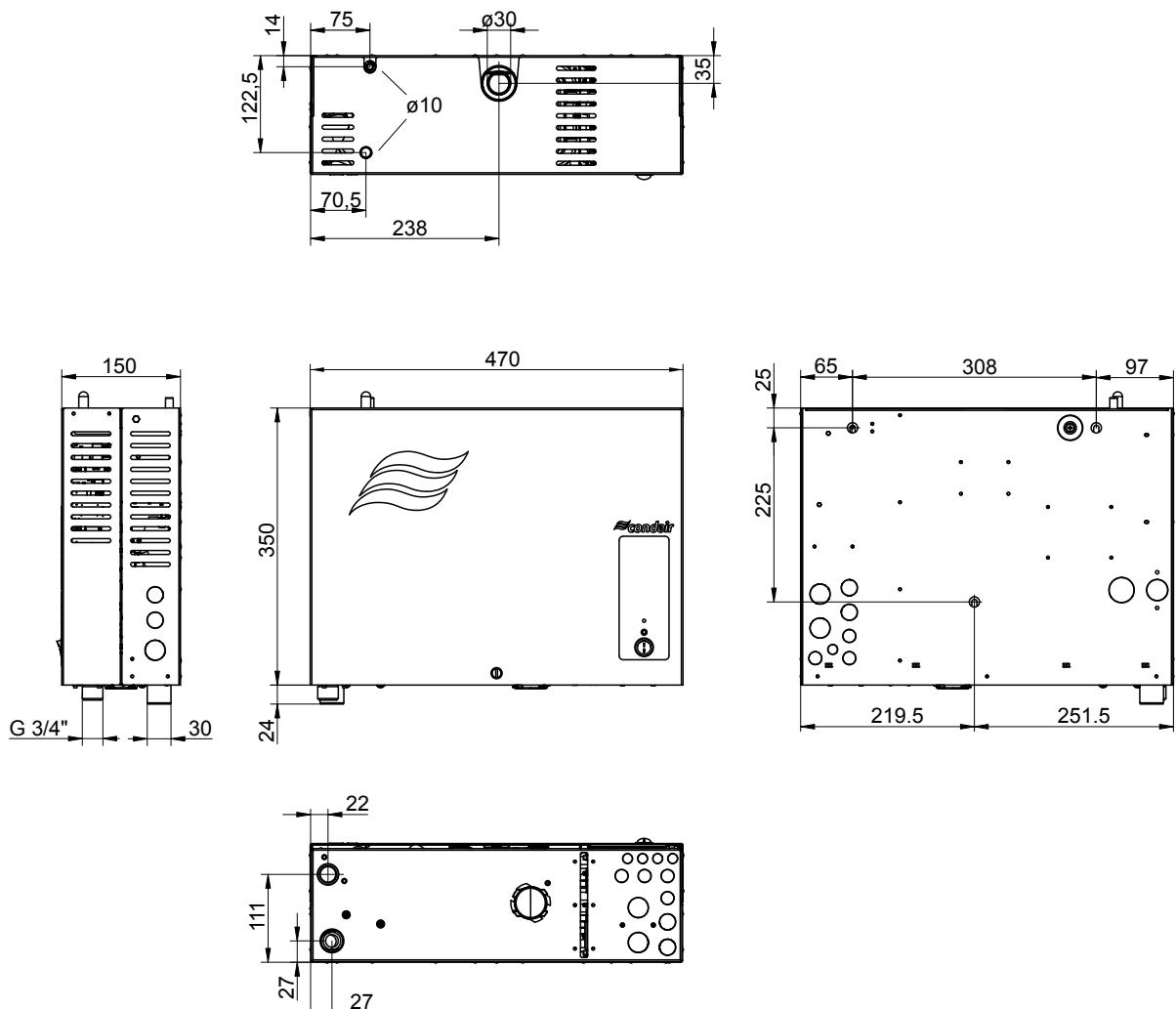

Fig. 29: Unit dimensions unit "Small" (dimensions in mm)

7.1.2 Unit dimensions unit "Medium" (Condair Omega 12...20)

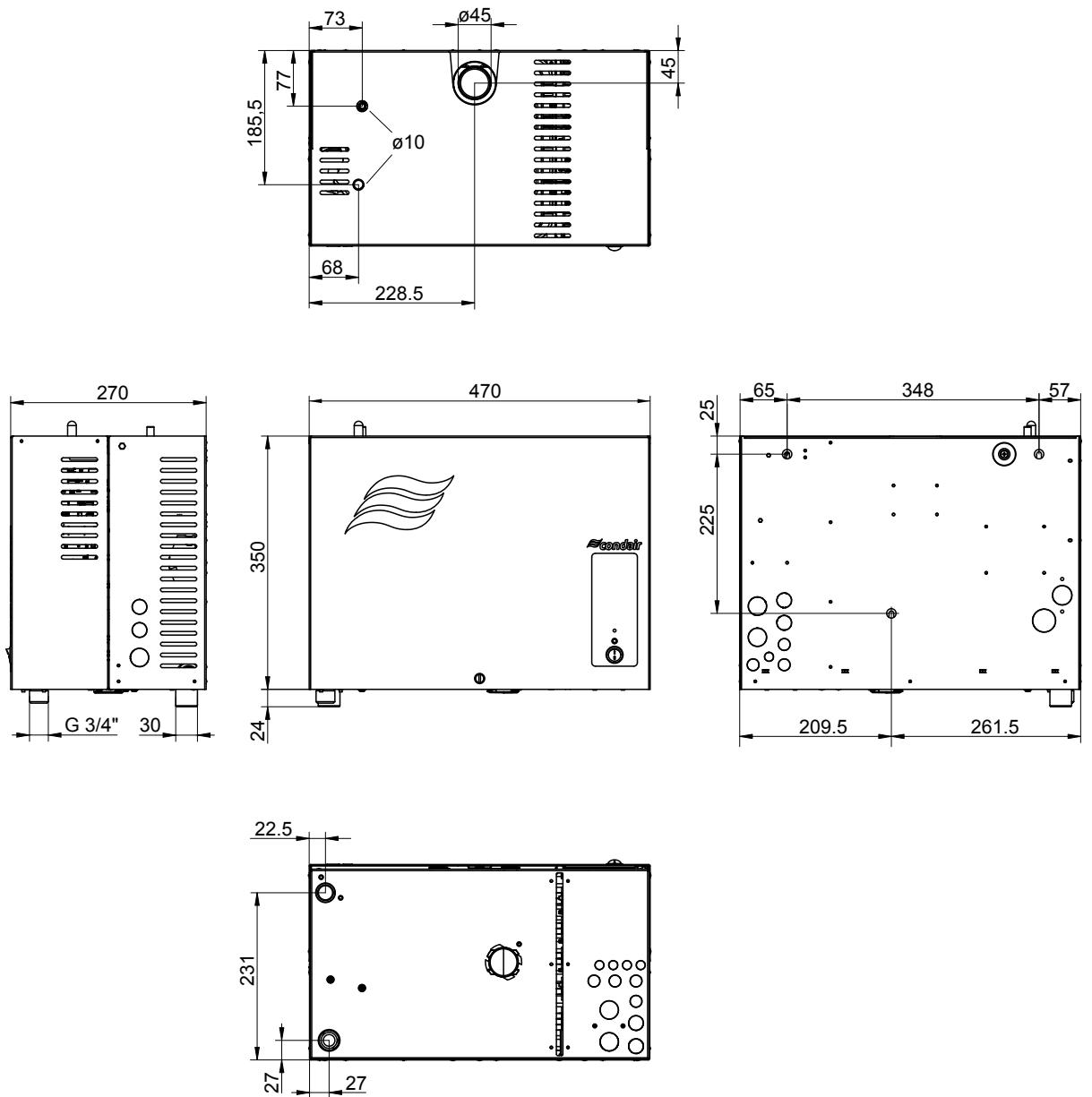
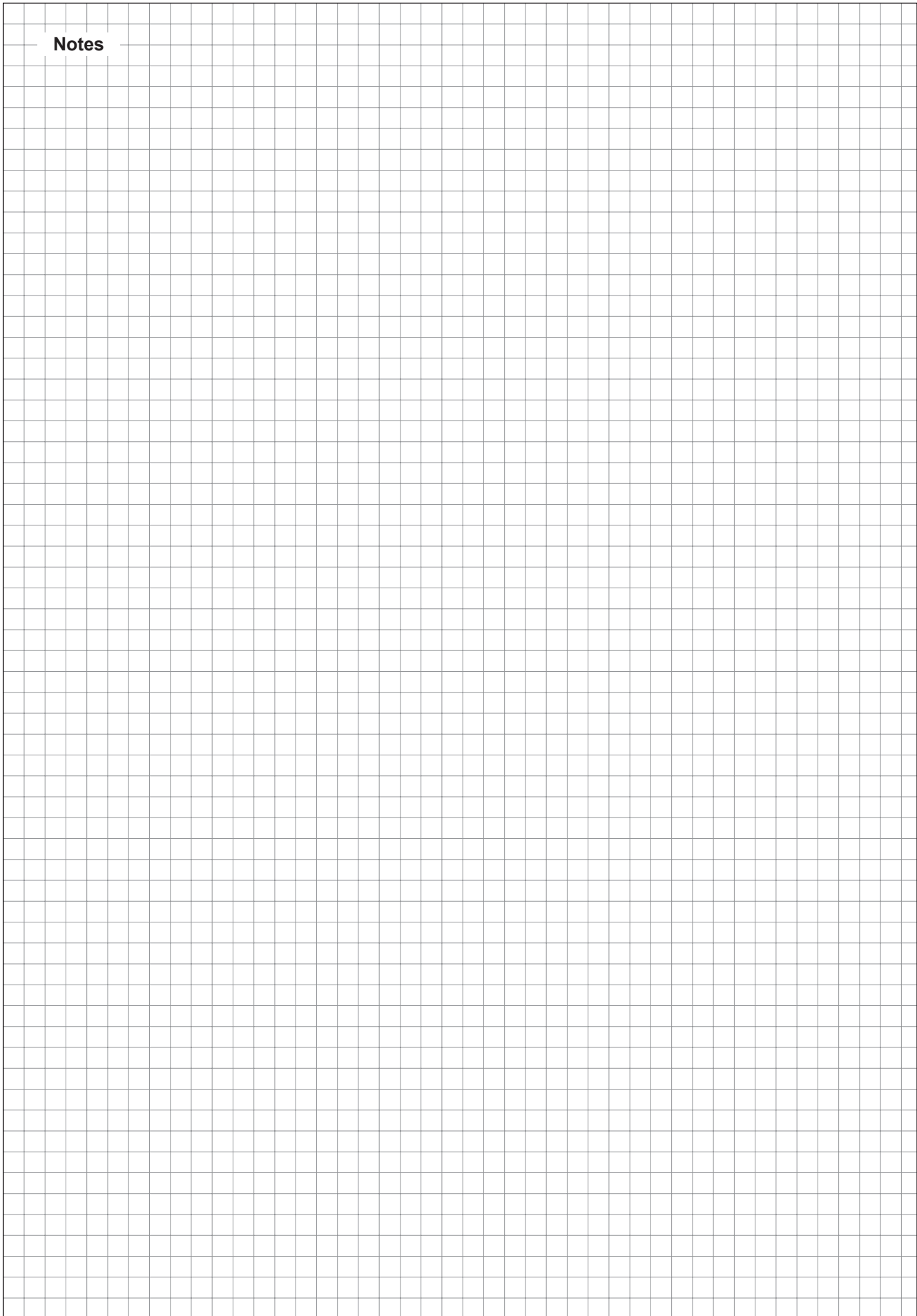

Fig. 30: Unit dimensions unit "Medium" (dimensions in mm)

Notes



Notes

Notes

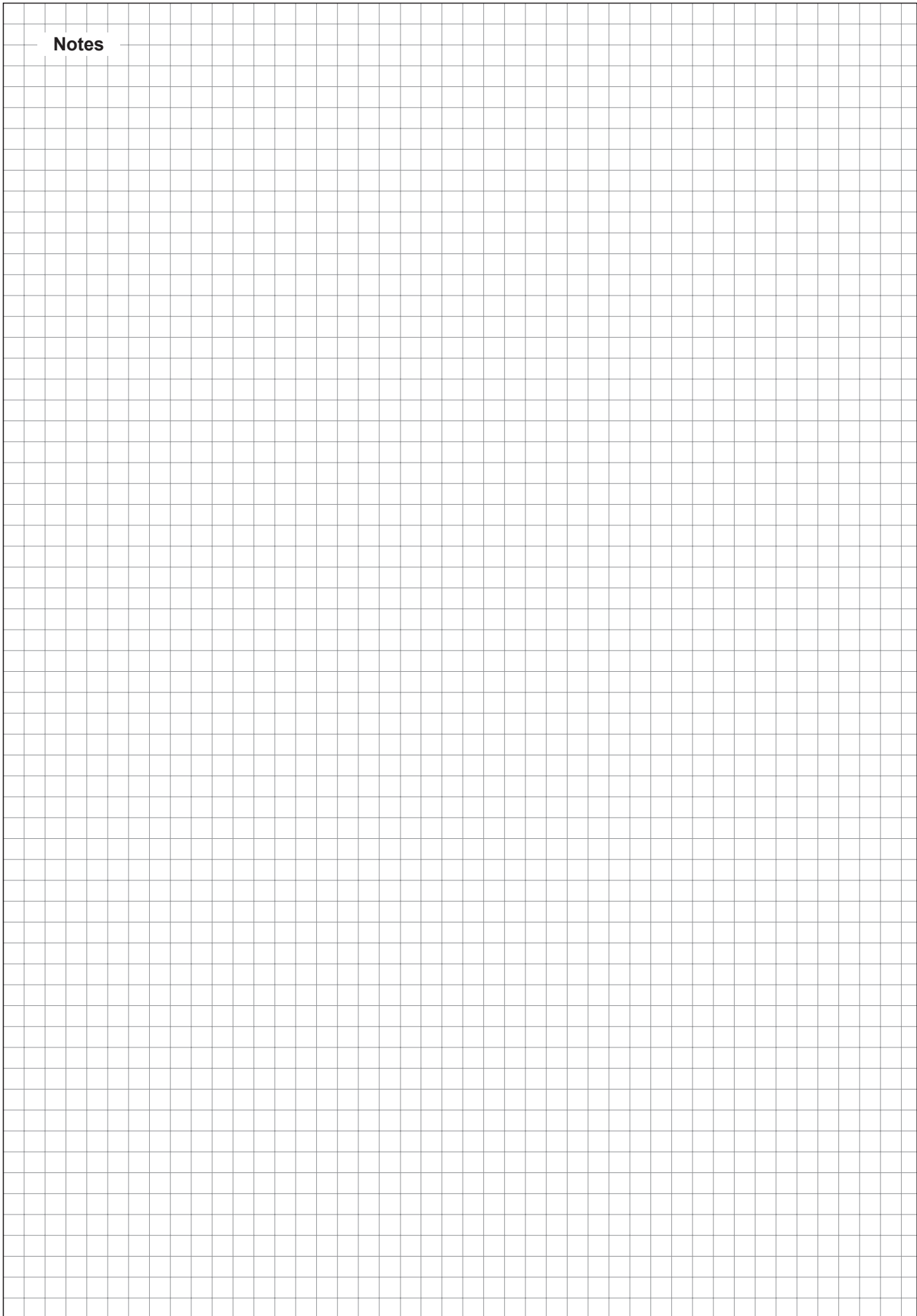

CONSULTING, SALES AND SERVICE:



CH94/0002.01

Condair Group AG
Gwattstrasse 17, 8808 Pfäffikon SZ, Switzerland
Phone +41 55 416 61 11, Fax +41 55 588 00 07
info@condair.com, www.condairgroup.com

The Condair logo, consisting of a stylized wave symbol followed by the word 'condair' in a bold, lowercase, sans-serif font.